



DESIGN GUIDE

PULTRUDED FIBRE REINFORCED
POLYMER (FRP) STRUCTURES
COMPOSITE FIBRE TECHNOLOGIES

VERSION 2 - 2024

WAGNERS

HEADINGS

PART ONE	INTRODUCTION	7	PART EIGHT	MEMBERS SUBJECT TO COMBINED ACTIONS	28
PART TWO	MATERIALS	9	PART NINE	CONNECTION DESIGN	30
PART THREE	DESIGN BASIS	16	PART TEN	DRIVEN PILES	32
PART FOUR	MEMBERS SUBJECT TO BENDING	22	PART ELEVEN	COMPONENT DESIGN	35
PART FIVE	MEMBERS SUBJECT TO AXIAL COMPRESSION	24	PART TWELVE	STRUCTURE DESIGN	36
PART SIX	MEMBERS SUBJECT TO AXIAL TENSION	26	APPENDICES		81
PART SEVEN	MEMBERS SUBJECT TO AXIAL TORSION	27	GLOSSARY		123

DISCLAIMER

The information provided in this publication, including any design capacities, calculations and tables, is specific to pultruded Fibre Reinforced Polymer (FRP) products supplied by Wagners CFT Manufacturing Pty Ltd ("Wagners Composite Fibre Technologies (CFT)"), and is subject to change without notice.

While every effort has been made and all reasonable care taken to ensure the accuracy of the material contained herein, Wagners Composite Fibre Technologies (CFT), the Authors, Editors and Publishers of this Publication shall not be held to be liable or responsible in any way whatsoever and expressly disclaim and liability or responsibility for any loss or damage costs or expenses howsoever incurred by any person whether the purchaser of this work or otherwise including but without in any way limiting any loss or damage costs or expenses incurred as a result of or in connection with the reliance whether whole or partial by any person as aforesaid upon any part of the contents of this publication.

Should expert assistance be required, the services of a competent professional person should be sought.

PRODUCT AVAILABILITY AND OTHER INFORMATION

It is expected that the content of this Design Guide for pultruded FRP structural sections will change over time as a result of improvements to the materials, properties and finishes of products, and due to changes to the product range. Therefore it is important to check that you are using the most up to date information by referring to the Wagners CFT website, wagnerscft.com.au



VISIT WAGNERS CFT WEBSITE
BY SCANNING THE QR CODE

TABLE OF CONTENTS

Preface	5	2.9	Storage and Handling	15
Standards and Guidelines Documents & References	6			
1. Introduction	7	3. Design Basis		16
1.1	General	3.1	General	16
1.2	Scope	3.2	Limit States Design	16
1.3	Design Standards	3.3	Time Effect Factor	17
1.4	Design Guide Layout	3.4	Capacity Reduction Factors	18
1.5	Units	3.5	Adjustment Factors for End-Use	18
1.6	Safety in Design	3.5.1	General	18
		3.5.2	Moisture Condition Factor	18
		3.5.3	Temperature Factor	18
		3.5.4	Chemical Environmental Factor	19
2. Materials	9	3.6	Creep	19
2.1	General	3.7	Fatigue	19
2.2	Manufacturing Process	3.8	Impact Resistance	20
2.3	Material Properties	3.9	Vibration & Dynamic Performance	20
2.3.1	Mechanical and Physical Properties	3.9.1	Vibration	20
2.3.2	Thermal Properties	3.9.2	Dynamic Performance	20
2.3.3	Fire Properties	3.9.2.1	Pedestrian Comfort	21
2.3.4	Electrical Properties	3.9.2.2	Wind Induced Excitation	21
2.3.5	Electromagnetic Properties	3.9.2.3	Material Damping	21
2.4	Dimensions and Section Properties	3.10	Seismic Design	21
2.5	Durability & Environmental Effects			
2.5.1	General			
2.5.2	Chemical Resistance			
2.5.3	UV Exposure			
2.5.4	Moisture & Humidity			
2.5.5	Temperature Effects			
2.5.6	Termites & Borers			
2.6	Tolerances	4. Members subject to Bending		22
2.6.1	Structural Hollow Sections	4.1	Design Section Moment Capacity	22
2.6.2	Bonded Rectangular Beams	4.2	Design Member Moment Capacity	22
2.6.3	Bonded I Girders	4.3	Design Shear Capacity	22
2.7	Painting Guidelines	4.4	Combined Bending and Shear	22
2.8	Defects	4.5	Design Bearing Capacity	22
		4.6	Deflection Calculations	23

TABLE OF CONTENTS (CONT.)

5. Members subject to Axial Compression	24		
5.1 Design Section Axial Compression Capacity	24		
5.2 Design Member Axial Compression Capacity	24		
5.2.1 Serviceability	24		
6. Members subject to Axial Tension	26		
6.1 Design Section Capacity in Axial Tension	26		
7. Members subject to Torsion	27		
8. Members subject to Combined Actions	28		
8.1 Combined Bending and Compression	28		
8.2 Combined Bending and Tension	28		
8.3 Combined Bending, Axial Compression and Torsion	28		
8.3.1 Hollow Sections	28		
8.3.2 Open Sections	29		
8.4 Combined Bending, Axial Tension and Torsion	29		
8.4.1 Hollow Sections	29		
8.4.2 Open Sections	29		
9. Connection Design	30		
9.1 Bolted Connections	30		
9.2 Riveted Connections	30		
9.3 Multiple Bolt Joint Groups and Interaction	31		
9.4 Detailing of Connections	31		
9.4.1 End Treatment at Supports and Load Points	31		
9.4.2 Grouted connections	31		
9.4.3 Additional Insert Requirements	31		
9.5 Connection Design Examples	31		
10. Driven Piles	32		
10.1 Methodology for Pile Design	32		
10.1.1 Structural Capacity	32		
10.1.2 Vertical Resistance	32		
		10.1.3 Lateral Resistance	32
		10.1.4 Pile Settlement	33
		10.2 Driven Pile Methodology	33
		10.2.1 Drop Hammer Design	33
		10.2.2 Vibratory/Pneumatic Design	33
		10.2.3 Detailing	34
		10.2.3.1 Pile Splices	34
		10.2.3.2 Pile Toe	34
		10.3 Driven Piles in Silts and Clays	34
		10.4 Driven Piles in Sand	34
		10.5 Pile Group Effects	34
		11. Component Design	35
		11.1 Decking	35
		11.2 Railing	35
		11.3 Stair Treads	35
		12. Structure Design	36
		Appendices	81
		Appendix A: Physical, Mechanical, and Sectional Properties of Wagners CFT Structural Sections	82
		Appendix B: Section and Member Capacities	91
		Appendix C: Connection Capacities	104
		Appendix D: FRP Composite Decking	115
		Appendix E: Wagners CFT CHS Piling Technical Data	118
		Appendix F: Accessories	119
		Glossary	123

PREFACE



Wagners Composite Fibre Technologies (CFT) is pleased to present this second edition of its “Design Guide for Pultruded FRP Structural Sections”. This Design Guide is intended for all structural design engineers who wish to design structures using Wagners CFT pultruded Fibre Reinforced Polymer (FRP) structural products. It provides engineers using this publication with all of the information required to design structures using Wagners CFT products with design methods and design capacities for all of the pultruded FRP structural products supplied by Wagners CFT.

The vision of Wagners CFT is not just to be a supplier of FRP structural products, but also to provide the market with innovative engineered structural solutions for many civil and structural applications where fibre composites have a distinct advantage. To support this vision, this Design Guide will be the primary member design publication, supported by a suite of other publications which will include many pre-engineered applications and building system designs.

The goal of these publications is to enable designers, certifiers, and builders to specify and use Wagners CFT products with ease, and with confidence in the quality and integrity of the data presented and the products supplied.

The properties and design capacities presented in this Design Guide are specific to the materials, manufacturing processes and fibre layups of the products supplied by Wagners CFT, and therefore do not apply to other products. Other manufacturers will not necessarily use the same materials, manufacturing process and fibre layups, resulting in different properties and capacities. Therefore, similar structural shapes produced by other manufacturers will not have identical properties and performance and are not to be designed using this manual.

STANDARDS AND GUIDELINE DOCUMENTS

AS1170 Australian/New Zealand Standard Parts 0 to 5 – Structural Design Actions as applicable.

AS2156.2:2001 Walking tracks Infrastructure design.

AS5100 Bridge Design.

ATS-5880 2023 Austroads Technical Specification, Fibre Reinforced Polymer Bridge Members.

ASCE 2010, Pre-Standard for Load & Resistance Factor Design (LRFD) of Pultruded Fibre Reinforced Polymer (FRP) Structures (Final), American Society of Civil Engineers, November 9. (Submitted to American Composites Manufacturers Associations (ACMA)).

Eurocomp 1996, Structural Design of Polymer Composites, Eurocomp Design Code and Handbook, ed. J.Clarke, E&FN Spon, London.

ACMA 2014, FRP Composites Grating Manual For Pultruded and Molded Grating and Stair Treads.

REFERENCES

Bank, LC 2006, *Composites for Construction*, John Wiley & Sons, New York, NY.

Cranitch, Lucy 2009, *Composites in Industrial Plants: An Introductory Guide*, GHD. (Funded by the Department of Employment, Economic Development and Innovation (DEEDI), the State of Queensland).

Clarke, John L, *Structural Design of Polymer Composites - Eurocomp Design Code and Handbook*.

Kara, S & Manmek, S 2009, *Composites: Calculating Their Embodied Energy, Final Report*, Life Cycle Engineering & Management Research Group, The University of New South Wales. (A multi-partner collaboration project led by the Department of Employment, Economic Development and Innovation (DEEDI), the State of Queensland).

Thompson, R 2012, *Practical Composites Design and Analysis*, Seminar, Composites Australia and Cooperative Research Centre for Advanced Composite Structures, Brisbane 19 September.

Zerbst, SDW 2009, *Temperature Effects on a Fibre Reinforced Polymer Material*, in fulfilment of the requirements of Courses ENG 4111 and 4112 Research Project towards the degree of Bachelor of Engineering (Mechanical), University of Southern Queensland Faculty of Engineering and Surveying, October.

INTRODUCTION



1.1 GENERAL

Pultruded Fibre Reinforced Polymer (FRP) structural sections are becoming more popular in many applications where their unique characteristics of strength and durability provide an advantage over other materials. While this material has been used in civil and structural applications for many years, there is a definite lack of design standards available to guide structural engineers.

Wagners Composite Fibre Technologies (CFT) manufacture and supply a range of pultruded FRP structural sections, and this Design Guide has been prepared to provide structural engineers with all of the design procedures and information for the structural design. The design procedures and the values in the design capacity tables have been derived for members and connections capacities using a mixture of test results and design calculations from ASCE Pre-Standard.

Any gaps in test information will have to be filled using the ASCE Pre-standard design rules.

1.2 SCOPE

This Design Guide for Pultruded FRP Structural Sections applies only to the pultruded FRP structural sections manufactured and supplied by Wagners CFT. The design capacities given in the tables do not apply to other similar composite products, because significant variability can occur by the use of different materials and fibre layup.

1.3 DESIGN STANDARDS

Eurocomp (1996) has been the accepted design standard for composites over many years, but it has some errors and is incomplete in some areas. Unfortunately, it has not been updated since its first publication. Since then, an ASCE Pre-Standard Draft

(2010) has been produced, but it still has not been finally edited and issued as a recognised standard. This Design Guide has been based mainly on the ASCE Pre-Standard because the methodology and terminology aligns more with what engineers in Australia are familiar with: Limit States Design.

All design capacity values presented in the capacity tables contained in this Design Guide are reference limit state design values with capacity reduction factors applied. As explained in a subsequent section certain adjustment factors have to be applied to these capacities to account for duration of loading, and the expected in service environmental conditions.

1.4 DESIGN GUIDE LAYOUT

The primary purpose of this Design Guide is to provide reference capacity tables for the various pultruded FRP structural sections produced and supplied by Wagners CFT. The tables of reference capacity are provided in the appendices at the end of the publication and include:

- » Structural hollow sections
- » Bonded structural sections
- » Decking
- » Bolted connections
- » Riveted connections

The section capacity tables present the reference section capacities for all design actions (bending, shear, compression, tension, bearing) and all Wagners CFT sections included in the one table. The member capacity tables present separate tables for each design action with each table including all the Wagners CFT sections for comparison and selection of a suitable section for the particular design action. It is believed that this arrangement will make it convenient for users to locate the relevant capacities and select appropriate members.

The body of the publication is a vital resource for all users to understand and apply the Wagners CFT design methodology to the design capacity tables in the appendices.

Part 1 provides general information on the Wagners CFT product and the philosophy of designing to this manual.

Part 2 provides general information on the physical and mechanical properties of the pultruded products, durability and environmental effects, and other information relating to the use of the products.

Part 3 gives the basis for the design of the pultruded profiles, how environmental effects influence the design capacities, and information on other design considerations such as creep, fatigue, and impact resistance.

Part 4 provides the methods to use this manual to design various types of structural members for bending action.

Part 5 provides the methods to use this manual to design various types of structural members for compression forces.

Part 6 provides the methods to use this manual to design various types of structural members for tension forces.

Part 7 provides the methods to use this manual to design various types of structural members for torsional action.

Part 8 provides the methods to use this manual to design various types of structural members for combined actions.

Part 9 provides the methods to use this manual for connection design.

Part 10 provides the methods to use this manual for design of Wagners CFT driven piles.

Part 11 provides example calculations using this manual for component design.

Part 12 provides example calculations using this manual for structure design.

1.5 UNITS

The units adopted for this Design Guide are consistent with those in the SI (metric) system. The base units used in the tables are:

PROPERTY	UNITS	SYMBOL
Force	kilonewton	kN
Length	Meter	m
Mass	kilogram	kg
Stress	Megapascal	MPa
Temperature	degrees Celsius	°C

Except for some minor exceptions, all values in the Tables are rounded to three (3) significant figures.

1.6 SAFETY IN DESIGN

The designers of structures have an obligation by law and duty of care to observe safety in design regulations and principles.

This means designers have to think about design and documentation solutions for reasonably foreseeable hazards that may occur as the structure is built, commissioned, used, maintained, repaired, refurbished or modified, decommissioned, demolished or dismantled and disposed or recycled.

It is the responsibility of users of this manual to exercise safety in design principles. The use of this manual does not relieve the designer in any way of their responsibility and duty of care for safety in design.

MATERIALS



2.1 GENERAL

FRP composites have proven themselves as the material of choice in high performance applications such as the aerospace and marine industries. As the use of FRP have become more common their benefits have been realised by other industries and their use and acceptance by civil engineers has greatly increased in recent years.

FRP composite materials offer high strength, low weight, and longevity as they are not prone to corrosion, rot or shrinkage unlike other materials more traditionally used by the construction industry. Wagners CFT is expanding the use of FRP in Australia and throughout the world, exporting products from Toowoomba Queensland to locations such as the United States, Europe, Middle East, Russia, and Malaysia.

Wagners CFT use the 'pultrusion process' to manufacture structural FRP sections. These sections are similar in geometry and shape to traditional cold-formed steel sections, but are made from glass fibres and vinyl ester resins. The material combination has been chosen by Wagners CFT to provide the best structural solution for an economical cost. The FRP sections of Wagners CFT can be classified as E40 Grade "equivalent" as per Table 1 of BS EN 13706-3:2002 (E) referenced Austroads Technical Specifications (ATS 5880) for FRP bridge members. Electrical-Corrosion Resistant (ECR) type glass has been selected as the initial building block for all Wagners FRP products. This high grade material has been selected for its impressive strength performance and workability. ECR type glass is also widely reported as having excellent chemical resistant characteristics. To bind the glass fibres together, Wagners CFT uses Vinyl Ester (VE) resin. VE resin has been selected over unsaturated polyester and epoxy resins because it provides strength and chemical resistant properties similar to epoxy resin to a significant cost advantage. In general Wagners CFT does not recommend the use of polyester resins for structural applications. Similar to timber, FRP composite materials have orthotropic properties.

2.2 MANUFACTURING PROCESS

Developed in the 1950's by the person considered by many to be "the father of composites," W. Brant Goldsworthy, pultrusion is the process of "pulling" raw composites through a heated die creating a continuous composite profile.

The term pultrusion combines the words, "pull" and "extrusion". Extrusion is the pushing of material, such as a billet of aluminium, through a shaped die, whereas pultrusion, is the pulling of material, such as fibre and resin, through a shaped die.

The pultrusion process starts with racks holding rolls of fibre roving (thread). The fibre reinforcement used by Wagners CFT is glass fibre. This raw fibre is pulled off the racks and is guided to the necessary shape, orientation and layers before entering a resin injection system. A surface veil is incorporated to improve surface finish and provide resistance to UV degradation.

The fibre reinforcement becomes fully injected (wetted-out) with the catalysed resin such that all the fibre filaments are thoroughly saturated with the resin mixture. This wetted fibre then enters the heated curing die. The heat initiates a chemical reaction in the resin which causes it to harden and the finished profile exits the die and is subsequently cooled. The movement for the process is created by puller clamps which act on the finished product and pull it on a continuous basis.

At the end of this pultrusion machine is a moving cut-off saw. The pultruded profiles are cut to the specific length and stacked.

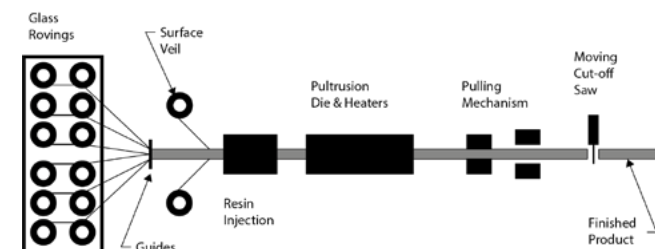

2.3 MATERIAL PROPERTIES

2.3.1 MECHANICAL AND PHYSICAL PROPERTIES

The mechanical and physical properties tabulated in Appendix A are based on coupon testing commissioned by Wagners CFT. The coupon tests were carried out on specimens taken from Wagners CFT relevant production sections. The coupon test results vary slightly between the different sections, hence material property tables are provided specific to each section.

2.3.2 THERMAL PROPERTIES

Thermal Expansion

The thermal expansion properties of fibre composites can vary significantly because of the wide range of constituent materials which are available.

Wagners CFT pultrudes Glass Fibre Reinforced Polymer (GFRP) products have a coefficient of thermal expansion of 5.03×10^{-6} /°C which is about 50% of the coefficient of expansion of steel.

Thermal Conductivity

Wagners CFT pultrudes GFRP products are good thermal insulators as they do not easily conduct heat. They have a coefficient of thermal conductivity which is typically less than about 1% of the coefficient for carbon steel.

2.3.3 FIRE PROPERTIES

Wagners FRP is a self-extinguishing material.

Wagners CFT have undertaken testing to:

- » ASTM E84 – Standard Test Method for Surface Burning Characteristics of Building Materials
- » ASTM D635 - Rate of Burning and/or Extent and Time of Burning of Plastics in a Horizontal Position

For applications that require additional prevention measures from fire attack, contact Wagners CFT directly to discuss coating options.

2.3.4 ELECTRICAL PROPERTIES

Wagners GFRP products do not conduct electricity. This is very advantageous for structures in the electricity transmission industry, and in other applications where electrical hazards exist.

GFRP sections are susceptible to the build-up of static electricity. This can be alleviated by using a carbon veil to provide an electrical path for grounding.

2.3.5 ELECTROMAGNETIC PROPERTIES

Wagners FRP products are nonmagnetic because they contain no metals.

2.4 DIMENSIONS AND SECTION PROPERTIES

Dimensions and section properties for CHS, SHS, RHS and BRS and BIS sections are included in Appendix A, and dimensional tolerances are presented in Section 2.6.

2.5 DURABILITY & ENVIRONMENTAL EFFECTS

2.5.1 GENERAL

Fibre Reinforced Polymers (FRP) can offer many advantages over other traditional materials especially in harsh environments due to its high durability. To ensure that the product performance and appearance is maintained over the life of the product, the following environmental effects must be taken into consideration.

2.5.2 CHEMICAL PROPERTIES

Wagners CFT pultrusions are made from vinyl ester resins. An extensive durability study has been undertaken on Wagners FRP composite sections considering various environmental conditions and chemical immersion and highlighting its excellent performance. The detailed test report can be provided upon request.

Vinyl ester resins provide very good corrosion performance in both acidic and alkaline environments and it is highly durable in standard atmospheric conditions.

2.5.3 UV EXPOSURE

Ultraviolet light will cause surface discoloration of FRP composite sections. Eventually, “fibre blooming” or fusing will occur if the product is left exposed to the sun long enough.

To combat deterioration of the FRP due to exposure to UV radiation, Wagners CFT profiles have a synthetic surface veil and are coated with a fluoropolymer paint system.

2.5.4 MOISTURE & HUMIDITY

Wagners CFT products perform very well in moist and high humidity environments. The automated manufacturing process ensures there are minimal voids in the cross section of the product, and therefore minimal water ingress.

Moisture ingress in exposed composites generally occurs through air voids and can weaken the FRP materials. The pultrusion process minimises the amount of air voids (typically 1% or less) in the composite, thus minimising water ingress. Wagners CFT has tested the Pultrusion for moisture absorption, with the results indicating that Wagners’ pultrusions offer very good resistance to moisture absorption.

2.5.5 TEMPERATURE EFFECTS

The pultruded FRP produced by Wagners CFT is manufactured using thermosetting polymers. These materials undergo a change from a rigid to a rubbery state when the temperature increases above what is called the glass transition temperature (T_g).

At temperatures approaching the glass transition temperature, the mechanical properties of the FRP will be reduced. It is recommended that the maximum service temperature for the pultruded profiles does not exceed a temperature of 22°C (40°F) less than the glass transition temperature. (i.e. T_g – 22°C) The ASCE Pre-standard specifies that for sustained temperatures above 60°C that testing is required.

While the effect of low temperatures does not directly affect the strength of Wagners CFT sections, low temperatures can cause “freeze – thaw” issues on many structural elements. Freeze-thaw becomes an issue for a material when that material is able to absorb moisture. Water expands by 9% when frozen, which applies tremendous force to any material attempting to confine it. Therefore the best way to prevent degradation from freeze-thaw is to prevent moisture ingress. Since Wagners CFT members absorb very little moisture, they are able to resist freeze-thaw actions very well. Wagners CFT has performed freeze-thaw testing for a period of 22 weeks (1 cycle per day) for bridge applications, with no loss of strength over that period.

2.5.6 TERMITES & BORERS

FRP composite materials are resistant to attack by termites and borers because they do not provide a food source.

2.6 DIMENSIONAL TOLERANCES

2.6.1 STANDARD STRUCTURAL SECTIONS

STANDARD STRUCTURAL SECTIONS					
Parameter	Tolerance	Illustration			
		CHS	SHS	RHS	FS
External Dimensions	$\pm 0.5\%$ with a maximum of ± 0.5 mm				
Thickness, t	± 0.5 mm				
Outside corner radius, r _o	± 0.5 mm				
Out-of-flatness (Flat Section only)	$\pm b_f / 150$				
Concavity, x ₁ Convexity, x ₂	$\leq 0.4\%$				
Squareness of sides	$90^\circ \pm 1^\circ$				
Twist, v	≤ 2 mm + 0.5 mm per metre length				
Straightness, e (in any one plane)	$\leq 0.1\%$ of total length				
Mass of a section length	$\pm 4\%$				
Length of a member, L	± 5 mm				

The tolerance on member length applies to manufactured product only. Tolerances on post-processed (fabricated) product are determined on a project by project basis.

2.6.2 BONDED STRUCTURAL SECTIONS

BONDED STRUCTURAL SECTIONS		
Parameter	Tolerance	Illustration
Deviation from verticality of a web, Δ_v	± 2 mm	
Off centre of a web, e	± 2 mm	
Out-of-flatness of a flange	$\pm b_f / 150$	
Straightness, e	0.1% of total length	
Mass of a section length	$\pm 4\%$	
Length of a member, L	± 5 mm	

NOTE: The tolerance on member length applies to manufactured product only. Tolerances on post-processed (fabricated) product are determined on a project by project basis. Contact Wagners for details.

2.6.3 BONDED I GIRDERS

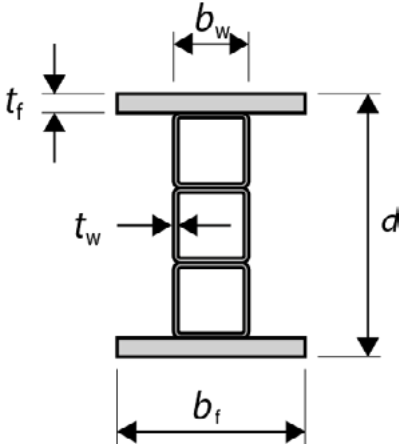
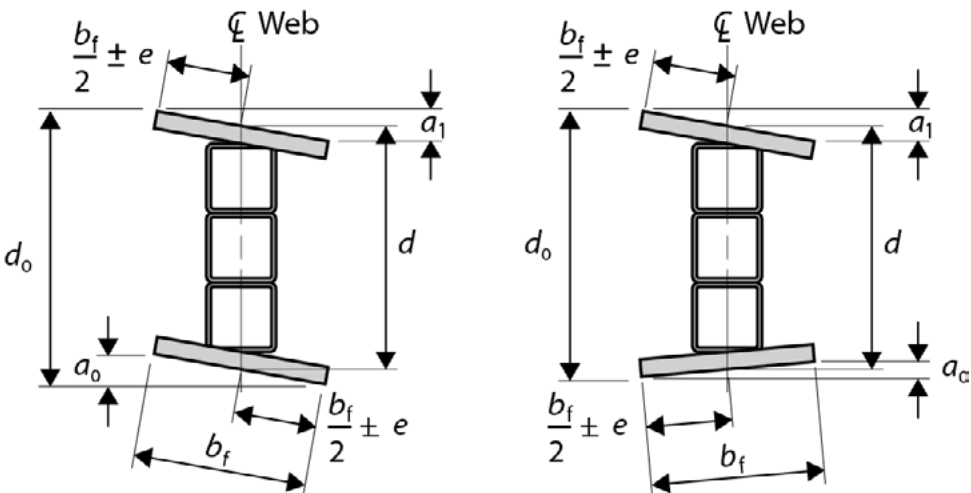
BONDED STRUCTURAL SECTIONS		
Parameter	Tolerance	Illustration
Depth, d	$\pm 0.5\%$ with a maximum of $\pm 0.5\text{mm}$	
Flange width, b_f	$\pm 0.5\%$ with a maximum of $\pm 0.5\text{mm}$	
Web width, b_w	$\pm 0.5\%$ with a maximum of $\pm 0.5\text{mm}$	
Flange thickness, t_f	$\pm 3\%$	
Web thickness, t_w	$\pm 10\%$	
Out-of-square of an individual flange, a_0 or a_1	$\pm 2\text{mm}$	
Total out-of-square of two flanges, a_0 or a_1	$\pm 4\text{mm}$	

NOTE: The tolerance on member length applies to manufactured product only. Tolerances on post-processed (fabricated) product are determined on a project by project basis. Contact Wagners for details.

2.7 PAINTING GUIDELINES

Wagners CFT pultruded profiles are supplied pre-painted. Additional coats of paint may be applied if desired.

Painting composites is as easy as painting steel or wood. Composites may be painted by any process (e.g. spray gun, brush, and roller), and are compatible for use with most paints. Two coats are recommended.

For further information on painting FRP products, contact Wagners CFT. It is proposed that a Painting Guide for Wagners CFT pultruded FRP products will be published in the future.

2.8 DEFECTS

ASTM Standard D4385 and EN 13706-2 cover the classification of, and acceptance criteria for visual defects in thermosetting reinforced plastic pultruded products.

For further information on acceptable and unacceptable defects, contact Wagners CFT. It is proposed that a Defects Guide for Wagners CFT pultruded FRP products will be published in the future.

2.9 STORAGE AND HANDLING

The following general guidelines for handling and storing FRP products are taken from ANSI: "Code of Standard Practice for Fabrication and Installation of Pultruded FRP Structures", published by American Composites Manufacturers Association, 2011 DRAFT (Ref. 2).

"Care should be exercised in the lifting and handling of pultruded FRP structures to prevent chipping, cracking, breaking, twisting or bending of the materials. If the materials are handled by forklift, the lift should be centered and evenly distributed over the forks. If materials are handled by an overhead crane, nylon lifting slings should be used.

Materials should be stored on cribbing, timbers or other dunnage capable of fully supporting the product and preventing twisting, bending or otherwise distorting of the product.

When pultruded FRP sections are stacked, the separating dunnage should be positioned directly above lower dunnage or supports so as not to over stress or induce cracking of the product.

Pultruded FRP structures should not be stored where temperatures exceed 50°C (120°F). Cold temperatures are not a concern to pultruded FRP structures; however, materials should be stored in a manner to prevent water from collecting in the product and freezing."

If any Wagners FRP products are damaged during handling, storage, construction, or in service, Wagners CFT must be contacted for advice on the acceptability or otherwise of the damage to ensure that the structural integrity of the product is not comprised.



3.1 GENERAL

This section of the design guide sets out the design basis adopted for Wagners CFT pultruded FRP products, and provides reference to the applicable specifications and standards.

There are two primary standards available for the design of pultruded FRP structures. These are Eurocomp (1996) and the ASCE Pre-Standard (2010). Originally, Wagners CFT had adopted the Eurocomp (1996) as the design standard for its products, but with the introduction of this Design Guide, it was decided to change to the ASCE Pre-Standard (2010). The reasons for this change include:

- » The ASCE Pre-Standard (2010) is a much more recent document, and as such it is expected to benefit from the up to date knowledge regarding the behaviour and design of fibre composites
- » The American methodology is more closely aligned with that in Australia
- » The notation in the ASCE Pre-Standard (2010) is much closer to that used in Australia
- » The use of time effect factors related to the design load combinations is preferred

It should be noted that the ASCE Pre-Standard (2010) is only a final draft document, and has not yet been adopted as a national standard in the USA or anywhere else. This document was funded by the American Composites Manufacturers Association (ACMA). It is recognised that this final draft has errors, and all due diligence has been applied to identify and correct these in the preparation of this Design Guide.

In this Design Guide, member and connection capacities are determined/calculated from a combination of experimental testing and theoretical approaches in accordance with the ASCE Pre-standard. The characteristic values were then calculated as per ASTM D7290, ASCE Pre-standard and AS1170.

In the preparation of this Design Guide, the decision was made to make slight changes to the notations used, where appropriate, to align more closely with that which Australian engineers are familiar.

3.2 LIMIT STATES DESIGN

This Design Guide is based on limit states design, as is the ASCE Pre-Standard (2010) which uses the Load & Resistance Factor Design (LRFD) format. All values presented in the capacity tables contained in this Design Guide are reference limit state values.

The design of structures and components requires the following two types of limit states to be considered:

- » The ultimate (strength and stability) limit states including combinations of actions from Permanent loads, Imposed loads, Wind loads, and Earthquake loads.
- » The serviceability limit states
- » The fatigue limit state
- » The fire limit state

For the strength limit state, all members and connections must be proportioned so that the design action effect (S^*) is less than or equal to the design capacity (ΦR_u) i.e.

$$S^* \leq \Phi R_u$$

Where R_u is the nominal capacity.

Φ is a capacity reduction factor depending on the particular action (e.g. bending, shear) and mode of failure (e.g. Material Rupture, Member Buckling, Local Buckling)

The design actions and combinations of actions to determine the design action effects (S^*) are given in AS/NZS 1170.0.

For the stability limit state, the structure as a whole, and any part of it, must be designed to prevent instability due to overturning, uplift or sliding as specified in AS/NZS 1170.0.

For the serviceability limit state, the structure and its components must be designed to limit deflection, vibration, bolt slip and deterioration as appropriate. The mean full section modulus can be used in the structural analysis in the serviceability limit state as per clause 2.4.3 (b) and 5.6 of ASCE LRFD Pre-standard 2010.

The design capacity: $\Phi R_u = \lambda C \Phi R_o$

Where λ is a time affect factor explained below

C is a factor to account for the end-use environmental effects from moisture (C_M), temperature (C_T) and chemical environment (C_{CH}).

$C = C_M C_T C_{CH}$. C_M , C_T and C_{CH} are explained below.

ΦR_o is the Reference Capacity obtained directly from the tables in Appendix C and D of this manual. The inclusion of Φ is to assist the users of this manual as Φ varies with the design action and governing mode of failure. It is up to the designer to apply the relevant time factor (λ) and end use factors (C_M , C_T and C_{CH}) to evaluate the design capacity relevant to a particular application and load type.

3.3 TIME EFFECT FACTOR

This manual utilises a time effect factor (λ) similar to the ASCE Pre-Standard that accounts for the creep-rupture phenomenon of pultruded FRP structural elements under sustained load and depends on the sustained stress level and the glass content of the material.

Time effect factors, taken from Table 2.3-1 of the ASCE Pre-Standard (2010) and adapted to the load combinations in AS/NZS 1170.0 are given in Table 2.6 below:

TABLE 2.6	
ULS Load Combination	Time Effect Factor (λ)
1.35G	0.4
1.2G + 1.5Q	0.6 when Q is from storage 0.8 when Q is from occupancy 1.0 when Q is from impact
1.2G + 1.5 Ψ_1 Q	0.4
1.2G + W _u + Ψ_c Q	0.75
0.9G + W _u	1.0
G + E _u + Ψ_c Q	1.0
1.2G + S _u + Ψ_c Q	0.75
Flood loads	0.8
Atmospheric ice loads	0.75

Note: When the full design load acts during the entire service life equal to or exceeding 50 years, the time effect factor shall be taken equal to 0.4.

It is expected in the future, on completion of further testing, that these λ factors will be amended.

3.4 CAPACITY REDUCTION FACTORS

The capacity reduction factor Φ varies depending on the action of the member type and the mode of failure. The design capacity reduction factors from the ASCE Pre-standard 2010 are tabulated below.

As mentioned above the capacity reduction factor Φ is included in the provided section, member and connection capacities.

ACTION	FAILURE MODE	CAPACITY REDUCTION FACTOR Φ
Members in Flexure	Material Rupture	0.65
	Local Instability	0.80
	Lateral Torsional Buckling	0.70
Compression members	Section Failure	0.80
	Member Failure	0.70
	Serviceability - initial crookedness	$1-500d_0/L$
Tension Members	Section Tension Rupture	0.65
Members in Shear	Material Shear Rupture	0.65
	Web Instability Failure	0.80
Bearing	Web Tensile Rupture	0.65
	Web Local Crippling	0.70
	Web Local Buckling	0.80
	Flexural failure of flange web junction	0.65
Torsion	Torsion shear rupture or buckling	0.70

Section 2.3.2 of the ASCE Pre-Standard allows a statistical calculation of the capacity reduction Φ based on test. This has been adopted in the connection capacities where 10 or more tests have been carried out. Where less than 10 tests have been done the AS1170.0 kt method has been used.

3.5 ADJUSTMENT FACTORS FOR END USE

3.5.1 GENERAL

For sustained end use conditions that differ from the reference conditions listed below, the reference strength and stiffness must be multiplied by the adjustment factors described below. Reference Conditions:

- (a) Short term loading
- (b) Structural member in air at Ambient temperature $23^{\circ}\text{C} \pm 2^{\circ}\text{C}$ and relative humidity $50 \pm 10\%$
- (c) Structural member untreated by protective coatings or systems
- (d) New structural member
- (e) Single member or connection without load sharing or composite action

These adjustment factors can vary at the discretion of the certifying/design engineer considering the application, additional experimental data and previous actual case studies.

3.5.2 MOISTURE CONDITION FACTOR

For vinyl ester material with sustained in service moisture conditions that vary from relative humidity $50 \pm 10\%$ the Moisture Condition Factor C_M shall be 0.85 for strength properties and 0.95 for elastic modulus. Otherwise $C_M=1.0$.

3.5.3 TEMPERATURE FACTOR

The temperature factor (C_T) is to account for sustained in-service temperature (T) higher than 38°C but less than $(T_g - 22^{\circ}\text{C})$. For sustained temperatures in excess of 60°C , C_T must be determined from tests.

For vinyl ester material and $38^{\circ}\text{C} < T \leq 60^{\circ}\text{C}$,

For Strength: $C_T = 1.444 - 0.0144T$

For Elastic Modulus: $C_T = 1.308 - 0.0108T$

For example for a sustained in service temperature of 40°C $C_T = 0.87$ for strength.

3.5.4 CHEMICAL ENVIRONMENTAL FACTOR

Generally Wagners CFT products have good resistance to aggressive environments as determined from preliminary tests and C_{CH} can be set at 1.0. If an application is in a particularly aggressive environment i.e. $ph < 2$ or $ph > 8$, please contact Wagners CFT for advice.

3.6 CREEP

Creep is the deformation of a material over time under a sustained load. Fibre composite materials have a tendency to experience creep. Timber is similar to fibre composites in that respect. The extent of creep depends on the constituent materials, particularly the resin matrix and fibre orientation. Pultruded profiles are considered to be reasonably creep resistant when the sustained loads are small.

The failure of pultruded FRP structural members under sustained load is governed by a creep rupture phenomenon. The time to failure is reduced as the sustained stress ratio is increased, and conversely, loads can be sustained for longer periods when the stress level is reduced. Increases in the temperature and moisture content of the member will also reduce the time to failure. Since glass does not creep, a higher volume of glass content in the FRP structural member will increase its resistance to creep effects.

Because the serviceability limit states will often govern the design, the service stresses will most likely be quite low relative to the stresses at which creep rupture damage might be expected to occur. As an estimate, ultimate stresses are generally in the range of 30-40% due to governing serviceability design.

Wagners CFT have implemented the following measures to ensure that creep effects are minimised:

- » Post-curing FRP materials to ensure that the glass transition temperature is much higher than the anticipated atmospheric temperature during the normal service life
- » Providing dominant fibre orientations to align with the direction of the predominant design stresses
- » Maintaining very high fibre/resin fractions by volume
- » Using unwoven fibres

- » Using high shear capacity resins and the pultrusion process that provides high interfacial bonding between the fibre and the matrix

Refer to Section 2.6.1 for adoption of the ASCE Pre-standard long-term factor K_{cr} applied to deflection calculations.

Further assessment of damage accumulation due to creep-rupture phenomenon can be found in the ASCE Pre-Standard in Section C2.3-8. The effect of creep is taken into account with the time effect factor discussed in Section 3.3 of this document. An assessment of the long-term stress utilisation of the member can be undertaken using Equation C2.3-9 from ASCE:

$$F_t/F_{ut} = 0.847 \cdot T_f^{-0.072}$$

Where:

F_t/F_{ut} is defined as the ratio of sustained applied stress to short-term ultimate tensile strength,

T_f is the time to failure under a constant stress ratio in hours

3.7 FATIGUE

Fibre Reinforced Polymers, like many other materials, are susceptible to the effects of fatigue under cyclic loading. Connections are critical for fatigue design, and particular attention must be given to the connection details used. Connections used in a fatigue situation may need to be tested.

The fatigue behavior of FRP composites is different to that of steel with which many designers are familiar and is more difficult to predict because of the complex nature of the material and loading conditions.

Bonded assemblies such as the Bonded I Girder (BIG), have been used in Wagners bridge structures which are designed for a 100-year design life. Fatigue testing has been carried out on these bridge structures up to 2 million cycles with no loss of connectivity observed in the bond lines.

Fatigue testing has also been undertaken on Wagners CFT Bridge Deck members to 2 million cycles in accordance with loading to AS5100.2 with no signs or deterioration of glue lines or member or connection integrity.

The calculation of fatigue performance of FRP members that are subject to repeated load and unload or reversal cycles shall be carried out in accordance with Clause 2.8 of the ASCE Pre-Standard.

$$(\Delta s)_{\text{limit}} = (C/N_f)^{1/m}$$

Where: $m = \text{constant}, 8.5$

$C = \text{constant that depends on geometry of the fatigue-critical detail}$

$N_f = \text{number of stress cycles the structure must sustain during service period}$

Fatigue does not need to be considered for seismic events or if the expected number of stress cycles during the service life of the structure is 4,000 or less.

3.8 IMPACT RESISTANCE

Fibre reinforced composites have good energy absorption capabilities. However, careful detailing for point impacts is required.

The Eurocomp Handbook (1996) states in clause 4.14.2:

“The impact strength of a particular FRP composite component is not related to a simple fundamental property of the material. The amount of energy absorbed in impact is a complicated function of material composition, component geometry, stress concentrations, impact load magnitude and velocity, ambient temperature and environmental conditions. At present, no simple method is available to predict impact behavior and therefore all impact design is based on product testing.”

Impact resistance of the FRP material can be calculated in accordance with testing to ASTM D7136 in accordance with ASCE Pre-Standard Clause 1.3.5.

3.9 VIBRATION AND DYNAMIC PERFORMANCE

3.9.1 VIBRATION

Due to the inherent light-weight nature of FRP Materials, they are susceptible to additional vibrations and comfort design criteria that the design engineer must investigate on a case-by-case basis.

Example of structures that require vibration investigation include but are not limited to:

- » Pedestrian boardwalks
- » Pedestrian bridges

- » Viewing platforms
- » Access/maintenance walkways and platforms
- » Cantilevered platforms

Vibration performance of FRP structural systems can be investigated using a number of methods at the design engineer’s disposal. These include:

- » Codified design guides and standard rules of investigation
 - o AS/NZS 1170.0 Appendix C – Guidelines for Serviceability Limit States
 - o American Institute of Steel Construction – Design Guide 11: Vibrations of Steel-Framed Structural Systems Due to Human Activity
 - o AS5100.2 – Bridge Design – Part 2: Design Loads
 - o British Standards BS 5400 Part 2: Part 14 BD37/01 Appendix B
 - o ASCE Pre-Standard for LRFD FRP Structures
- » Investigation of first and subsequent natural frequencies and keeping these generally above 5Hz and investigating further when below 5Hz

3.9.2 DYNAMIC PERFORMANCE

More complex FRP structures such as long-span pedestrian bridges, tall, slender boardwalks above ground and large cantilever decks should be investigated for their dynamic performance using the appropriate design software. These models should take into account modal mass of the system including superimposed dead loads, self-weight of materials, allowance for bolts, washers, nuts, Wagners CFT inserts, handrails, balustrades and any other permanent loading.

In a similar fashion to vibration design of FRP structures, dynamic design of footbridges also has codified and non-codified procedures available for use.

There are two main dynamic performance topics that the design engineer will need to investigate:

- 1) Pedestrian comfort
- 2) Wind induced excitation

3.9.2.1 PEDESTRIAN COMFORT

There are a number of sources for the design engineer to investigate pedestrian comfort. These include, but are not limited to:

- » UK National Annex to EN1991-2
- » SETRA 2006 - The Technical Department for Transport, Roads and Bridges Engineering and Road Safety for France
- » AASHTO – LRFD Guide Specifications for the design of pedestrian bridges

3.9.2.2 WIND INDUCED EXCITATION

For wind induced excitation, the design engineer will need to investigate the dynamic and structural performance of the structure under vortex excitation and divergent amplitude response.

Information on these phenomenon can include, but are not limited to:

- » British Standards BS 5400 Part 2: Part 3 BD49/01 – Design Rules for Aerodynamic Effects on Bridges
- » Canadian Standards CSA S6 – Canadian Highway Bridge Design Code

In lieu of codified or research paper availability for the style of proposed structure, the design engineer may need to investigate the performance of the FRP structures using Computational Fluid Dynamic (CFD) software.

3.9.2.3 MATERIAL DAMPING

Wagners CFT have undertaken material damping testing to ASTM E756.

The damping ratio of Wagners CFT FRP materials is noted as 0.62% for applications in the 20 degree C to 30 degree C temperature range.

Damping ratios for use in modelling vary depending on the type of structure and geometric arrangement. A sensitivity analysis using varying damping ratios should be undertaken by the design engineer. The estimated ranges for damping vary from 1% to 4%.

FRP Structures that appear to be sensitive to dynamic actions from pedestrians or wind excitation may be required to allow for additional damping by use of additional mass or damping systems.

3.10 SEISMIC DESIGN

Wagners CFT products are brittle materials and have little to no ductility demand available for seismic design. Wagners CFT recommends that all FRP members and connections are elastically designed with respect to seismic actions in accordance with AS1170.4 or NZS1170.5.

Wagners CFT structures are comparatively very light compared to steel or concrete structures and generally attract only small inertial forces from seismic actions.

These aspects do not preclude FRP materials from typical seismic engineering design procedures such as drift determination, P-Delta effects or assessment to seismic codes by using method of parts and components. It is the responsibility of the design engineer to verify the structure(s) are safe for seismic actions using FRP materials using engineering judgement.

MEMBERS SUBJECT TO BENDING



4.1 DESIGN SECTION MOMENT CAPACITY

The design member moment capacity

$$\Phi M_s = \lambda C \Phi M_{os}$$

ΦM_{os} is the reference section capacity tabulated in Appendix B. It is up to the designer to apply the applicable time (λ) and end use adjustment factors (C_M , C_T and C_H).

4.2 DESIGN MEMBER MOMENT CAPACITY

The design member moment capacity

$$\Phi M_b = \lambda C \Phi M_{ob}$$

ΦM_{ob} is the reference section or member capacity tabulated in Appendix B. It is up to the designer to apply the applicable time (λ) and end use adjustment factors (C_M , C_T and C_H).

4.3 DESIGN SHEAR CAPACITY

The design shear capacity of the pultruded FRP sections shear capacity

$$\Phi V_u = \lambda C \Phi V_o$$

where ΦV_o is determined from the reference section capacities tabulated in Appendix B.

It is up to the designer to apply the applicable time (λ) and end use adjustment factors (C_M , C_T and C_H).

The section shear capacity is the result of:

- » Shear rupture

- » Web Shear Buckling
- » A combination of the above

4.4 COMBINED BENDING AND SHEAR

While the ASCE Pre-standard does not specifically provide a design rule for bending moment and shear interaction, The Structural Plastics Design Manual (ASCE, 1984, p. 667) referred to by Bank⁴ recommends the following equation which we recommend until testing for bending – shear interaction is carried out.

$$(M^*/\Phi M_u)^2 + (V^*/\Phi V_u)^2 \leq 1.0$$

Where ΦM_u is the minimum of ΦM_s and ΦM_b

4.5 DESIGN BEARING CAPACITY

The design bearing capacity of the pultruded FRP section equals $\lambda \Phi_v R_n$ where ΦR_n is determined from the reference bearing capacities tabulated in Appendix B as applicable and multiplied by the end use adjustment factors. The section capacity determined from test is the result of

- » Tensile Web Rupture
- » Web Crippling
- » Web Compression Buckling
- » Flange Flexural Failure
- » A combination of the above

4.6 DEFLECTION CALCULATIONS

Pultruded Fibre reinforced polymer (FRP) members have a high tensile strength, but a relatively low longitudinal modulus of elasticity – up to about 1.5 times that for dry hardwood timbers. Therefore, when used as beams, the design is normally governed by deflection.

The deflection criteria for any particular application are given in the applicable loading or design standards, and are not covered in this publication.

As for timber, the deflection of FRP members is influenced by a number of factors such as:

- » Duration of load
- » Temperature
- » Moisture
- » Chemical environment

The effect of the duration of load is termed creep and is discussed in Section 3.5. The effect of temperature, moisture and chemical environment on the modulus of elasticity of the FRP is discussed in Section 3.4.

Because of the lower longitudinal and shear moduli of elasticity of pultruded Fibre Reinforced Polymers, deflection calculations also need to take into account shear deformations which become significant at span / depth ratios less than about 20. The standard formula for calculating the deflection of beams due to bending is

$$\Delta = k_1 WL^3/EI$$

where:

- W = total vertical load on the beam
- E = modulus of elasticity
- I = second moment of area of the cross-section
- k_1 = a factor depending on the load configuration and beam end conditions

Deflections of flexural members bent about their strong axis shall be determined using the full-section flexural modulus (E) when provided. If not, it can be taken as the tensile modulus obtained from small scale coupons testing.

The formula for calculating the shear deformations is:

$$\Delta = k_2 WL/GA$$

where:

- W = total vertical load on the beam
- G = in-plane shear modulus taken as $G_{tr} A_g/A$
- A_g = gross area of the section
- A = shear area of the cross-section = Area of the webs
- k_2 = a factor depending on the load configuration and beam end conditions

The total deflection is the sum of the deformations due to bending and shear, and is given by:

$$\Delta = k_1 WL^3/EI + k_2 WL/GA$$

Refer to ASCE (2010) Clause C2.6. In accordance with ASCE Pre-standard Clause 2.6.1 total long term deflection D is to be calculated from :

$$D = D_{st} K_{cr}(t)$$

Where

D_{st} is the short term deflection

And

$K_{cr}(t)$ is a deflection amplification factor

$K_{cr}(t) = 1 + t^{1/4} / 6$, t is in years

MEMBERS SUBJECT TO AXIAL COMPRESSION



THE DESIGN CAPACITY OF MEMBERS IN AXIAL COMPRESSION IS THE MINIMUM VALUE OF THE SECTION CAPACITY AND MEMBER CAPACITY GIVEN IN THE FOLLOWING SECTIONS.

5.1 DESIGN SECTION CAPACITY IN AXIAL COMPRESSION

The design section capacity in axial compression:

$$\Phi N_s = \lambda C \Phi N_{0s}$$

where ΦN_{0s} is determined from the reference section capacities tabulated in Appendix B. It is up to the designer to apply the applicable time (λ) and end use adjustment factors (C_M , C_{Tr} and C_H).

5.2 DESIGN MEMBER CAPACITY IN AXIAL COMPRESSION

The design member capacity in axial compression:

$$\Phi N_s = \lambda C \Phi_c N_{0c}$$

ΦN_{0c} is determined from the reference section capacities tabulated in Appendix B.

It is up to the designer to apply the applicable time (λ) and end use adjustment factors (C_M , C_{Tr} and C_H).

5.2.1 SERVICEABILITY

In addition to the ULS strength check, ASCE Pre-standard imposes a limit on the serviceability compression force as follows:

$$P_s \leq \phi_0 \frac{\pi^2 E_L}{\left(\frac{k_e L}{r}\right)^2} A_g \leq 0.3 f_{Lc} A_g$$

where:

P_s	=	compression force due to serviceability load combinations
Φ_0	=	capacity reduction factor that accounts for the initial out-of-straightness of the compression member
	=	1 – 500 (δ_0 / L)
(δ_0 / L)	=	initial out-of-straightness fraction guaranteed by the pultrusion manufacturer
E_L	=	longitudinal compression elastic modulus of the flange or web, whichever is smaller
k_e	=	effective length factor
L	=	length of the member
r	=	radius of gyration
A_g	=	gross area of the cross section
f_{Lc}	=	minimum longitudinal compressive strength of all elements comprising the cross section

The ASCE pre-standard specifies the load combinations to use for the check as:

$$G + (Q \text{ or } 0.5S)$$

$$G + 0.5Q + 0.4 W_u$$

$$G + 0.5Q$$

The compression member serviceability limits are included in Appendix B for the range of Wagners CFT CHS, RHS, SHS and BIS members.

MEMBERS SUBJECT TO AXIAL TENSION



6.1 DESIGN SECTION CAPACITY IN AXIAL TENSION

The design section capacity in axial tension:

$$\Phi N_t = \lambda C \Phi N_{ot}$$

Where ΦN_{ot} is determined from the tables in Appendix B.

It is up to the designer to apply the applicable time (λ) and end use adjustment factors (C_M , C_T , and C_H).

To minimize damage during transportation and erection, it is recommended that the slenderness ratio (L/r) of tension members does not exceed 300.

MEMBERS SUBJECT TO TORSION



Members subject to torsion are not included in this version of the manual. It is proposed that testing and design information for torsion members using Wagners CFT sections will be added to a future edition.

It is strongly advised to the designer that torsion in members is eliminated by use of additional strutting and restraining members and connections in a similar fashion to typical steel framing design.

Full scale testing can be undertaken at Wagners CFT testing facility to investigate the torsional performance of the FRP structural sections for specific projects and/or applications.

MEMBERS SUBJECT TO COMBINED ACTIONS



8.1 COMBINED BENDING AND COMPRESSION

When a member is subject to combined axial compression and bending moments about the x-axis and / or the y-axis, the following interaction formula must be satisfied:

$$\frac{N^*}{\phi N_c} + \frac{M_x^*}{\phi M_{bx}} + \frac{M_y^*}{\phi M_{by}} \leq 1.0$$

where:

N^*	= design axial compression force
M_x^*	= design bending moment about the x-axis
M_y^*	= design bending moment about the y-axis
ϕN_c	= design member capacity in axial compression
ϕM_{bx}	= design member moment capacity about the x-axis
ϕM_{by}	= design member moment capacity about the y-axis

8.2 COMBINED BENDING AND TENSION

When a member is subject to combined axial compression and bending moments about the x-axis and / or the y-axis, the following interaction formula must be satisfied:

$$\frac{N^*}{\phi N_t} + \frac{M_x^*}{\phi M_{bx}} + \frac{M_y^*}{\phi M_{by}} \leq 1.0$$

where:

N^*	= design axial compression force
M_x^*	= design bending moment about the x-axis
M_y^*	= design bending moment about the y-axis
ϕN_t	= design member capacity in axial tension
ϕM_{bx}	= design member moment capacity about the x-axis
ϕM_{by}	= design member moment capacity about the y-axis

8.3 COMBINED BENDING, AXIAL COMPRESSION AND TORSION

8.3.1 HOLLOW SECTIONS

When a hollow section member is subject to combined axial compression, torsion and bending moment about the x-axis or y-axis, the following interaction formula must be satisfied:

$$\frac{N^*}{\phi N_c} + \frac{M^*}{\phi M_b} + \left(\frac{M_z^*}{\phi M_z} \right)^2 \leq 1.0$$

where:

N^*	= design axial compression force
M^*	= design bending moment about the x-axis or y-axis
M_z^*	= design torsion moment
ϕN_c	= design member capacity in axial compression
ϕM_b	= design member moment capacity about the x-axis or y-axis
ϕM_z	= design member torsion capacity about the longitudinal z-axis

8.4 COMBINED BENDING, AXIAL TENSION AND TORSION

8.4.1 HOLLOW SECTIONS

When a hollow section member is subject to combined axial compression, torsion and bending moment about the x-axis or y-axis, the following interaction formula must be satisfied:

$$\frac{N^*}{\phi N_c} + \frac{M^*}{\phi M_b} + \left(\frac{M_z^*}{\phi M_z} \right)^2 \leq 1.0$$

where:

- N^* = design axial tension force
- M^* = design bending moment about the x-axis or y-axis
- M_z^* = design torsion moment
- ϕN_c = design member capacity in axial tension
- ϕM_b = design member moment capacity about the x-axis or y-axis
- ϕM_z = design member torsion capacity about the longitudinal z-axis

8.4.2 OPEN SECTIONS

CFT open section members are not recommended to carry torsion.

CONNECTION DESIGN



Wagners CFT has a number of options available for connection of FRP members to themselves and to other materials. Generally the connection solution will encompass stainless steel components as the application of the material is favoured among aggressive environments such as coastlines and inside industrial / manufacturing environments. Standard mild or hot dip galvanised components can be used at the discretion of the designer and provide no additional capacity changes from the capacities shown in Appendix C.

The aim of FRP connection design is to keep things as simple as possible and ensuring load paths are not convoluted. There are also some basic principles that Wagners CFT follow on all projects to ensure the safety and longevity of the structure is maintained through connection design.

Wagners CFT manufactures anti-crush block inserts that are made of PET/PBT blend with 50% glass fibre reinforcement. These inserts form a perfect-fit cube inside a Wagners CFT SHS product and increase bolt shear capacities. They also provide crushing resistance at support reactions. Also available are stainless steel tube bush-inserts which can substitute for Wagners CFT block inserts. These bush inserts are mainly installed at connections of CHS members, and also in SHS sections where using block inserts is not practical and the shear force is within the design capacity. All bolted connections require at a minimum

- a) bush insert for anti-crush and shear connection, or
- b) a Wagners CFT block insert at all other bolted connections.

Wagners CFT has undertaken testing of bolted connections with and without inserts.

Inserts are provided to improve the load capacity of bolted connections particularly for loads transverse to the main fibre direction. Furthermore, Wagners CFT anti-crush block inserts can be glued in place following Wagners CFT procedures for higher connection capacities due to the improved stress transfer between inserts and FRP.

9.1 BOLTED CONNECTION CAPACITY WITHOUT INSERTS

Bolted connections form the basic connection design for major members of boardwalks, viewing platforms, walkways, jetties and pedestrian bridges. Typically, everything under the joist location will be bolted connections with anti-crush inserts. anti-crush inserts can be inserted to:

- 1) Increase crushing resistance
- 2) Increase bolt shear capacity
- 3) Prevent wall collapse due to torquing requirements of bolts complete with nut and washer assemblies

Wagners CFT recommend that all bolted connections are designed with a Wagners CFT anti-crush insert to prevent bolt tear out and bolt hole elongation due to high loads (to be investigated by the design engineer).

Appendix C contains capacities of bolted connections with and without inserts.

All bolted connections should be completed with a locking nut in the form of a single lock nut or double nut to prevent loosening of connections over time.

9.2 RIVETED CONNECTIONS

Riveted angle bracket plate connections are typically used on Wagners CFT structures for:

- 1) Lightly loaded shear and axial connection
- 2) Joist to bearer connections

- 3) Handrail to handrail post connections
- 4) Truss members using fish-plates

Wagners CFT can supply stainless steel rivets and a range of stainless-steel connecting plates for this connection type.

Typical stainless steel rivet plates are 3mm thick for typical angle brackets and trussed bridge framing connections. The design of angle brackets can be undertaken to AS4100 for mild steel or AS4673 for stainless steel applications.

The use of riveted fish-plates in truss structure applications have undergone fatigue testing to 2 million cycles with no noticeable signs of fatigue failure in the rivets or FRP material.

Appendix C contains capacities of riveted connections.

9.3 MULTIPLE BOLT GROUP JOINT EFFECTS AND INTERACTION CAPACITY

Bolted connections and rivets capacities have been designed in accordance with ASCE pre-standard. As such, bolt group joint effects have been taken into account for joints where single bolt actions are exceeded. Refer Appendix C.

9.4 DETAILING OF CONNECTIONS

Connection detailing and design are an extremely important focus for engineers working on FRP products and structures.

There are a few key rules to maintain while designing FRP connections. These rules are to be in addition to typical connection design rules that the designer may use for other materials such as timber and steel connections.

- » End treatment at supports
- » Grouted connections
- » Concentrated loads at any point along member
- » No clamping of FRP flanges (if using an BIG product)
- » All bolted connections to have an insert

9.4.1 END TREATMENT AT SUPPORTS AND POINT LOADS

Wagners CFT recommend that all members and structures are adequately treated for potential of wall compression and general shear failure by ensuring a Wagners CFT insert block is installed at all support reactions or load bearing points of contact.

The design engineer should also verify the extent of shear load transfer through the web's of FRP members to ensure that they have adequate "length" of inserts/bearing to prevent the walls from collapsing. This is especially important with multiple bonded members forming larger beams carrying high loads. This can be completed by using first principles or an FEA model in more heavily loaded or difficult scenarios.

Table B-7 indicates characteristic capacities for SHS members with and without inserts (note insert hole position changes the result). Refer to Appendix E for the accessories used with Wagners CFT pultruded members.

9.4.2 GROUDED CONNECTIONS

Where it is not feasible or practical to use Wagners CFT anti-crush inserts, Wagners CFT recommends grouting of support and high point load regions to ensure crushing of webs is prevented.

The capacities of the grouted section will be presented in the next Design Guide version. Please contact Wagners CFT for inquiries.

9.4.3 ADDITIONAL INSERT REQUIREMENTS

As discussed at the start of Chapter 9, anti-crush inserts provide a nominal shear capacity increase for bolted connections. If the designer requires additional capacity from these connections, they can nominate the use of additional rivets which are fixed into the side position of the anti-crush inserts and FRP wall. These additional fixings couple with the bolt/FRP interaction and insert/FRP interaction provide increased capacities.

9.5 CONNECTION DESIGN EXAMPLES

Refer to Section 4 of the Design Example (Part 12).

DRIVEN PILES



10.1 METHODOLOGY FOR PILE DESIGN

The FRP sections of Wagners CFT can be used for the foundation support systems on numerous structures. In the past, Wagners CFT has used FRP materials in the following manner for foundations:

- » Driven piles
- » SHS's in bored piers
- » Micropile and cap systems
- » Mudsills

Driven FRP piles are a very effective form of foundation system and can drastically save on site works.

Driven FRP piles can be designed in a similar manner to other driven pile materials such as timber, steel and pre-stressed concrete.

The piles are to be assessed for a number of compliances to ensure safe design has been achieved. These include:

- » Structural capacity of the pile
- » Geotechnical vertical capacity
- » Geotechnical lateral capacity
- » Geotechnical settlement of the pile
- » Geotechnical pile group effects

10.1.1 STRUCTURAL CAPACITY

The structural capacity of FRP piles can be carried out in accordance with Section 9.1 based upon axial compression loads derived from the pile driving formula in Section 10.2.1

The effective length of the piles will need to be taken into consideration depending on the piling rig set up and minimum pile length specified for use while piling.

Connection of the FRP pile splice can be designed in accordance with Section 10.1.

10.1.2 VERTICAL RESISTANCE

Vertical pile resistance can be calculated using industry best practice for a single pile acting with skin friction and end bearing resistance.

These calculations should be undertaken to AS 2159.

The design engineer is to take into account the findings from the appropriate site-specific geotechnical reports and make allowance for specialty design items including but not limited to:

- » Negative skin friction
- » Liquefaction potential of ground material
- » Kinematic pile design for seismic actions
- » High settlement potentials
- » Low skin friction values

10.1.3 LATERAL RESISTANCE

Lateral pile resistance can be calculated using industry best practice for a single pile acting as a free or fixed pile head depending on the geometric structural arrangement.

These calculations should be undertaken to AS 2159.

The design engineer is to take into account the findings from the appropriate site-specific geotechnical reports undertake lateral pile design identifying cohesive, cohesionless, or rock material including but not limited to the following methods:

- » Broms

- » Brinch-Hansen
- » P-y pile analysis
- » Finite Element Analysis using 2D or 3D software if required

10.1.4 PILE SETTLEMENT

Vertical pile settlement can be calculated using industry best practice for a single pile based on elastic pile settlement theory using the FRP pile and second moment area of the structural pile, along with soil modulus values for the intended founding strata.

Pile head and shaft mobilisations are to be within limits identified by the geotechnical report or acceptable to the qualified design engineer.

10.2 DRIVEN PILE METHODOLOGY

10.2.1 DROP HAMMER DESIGN

Wagners CFT have had success using the drop hammers for the design and installation of driven FRP piles for a number of years.

There are a number of methods the design engineer can use to estimate geotechnical vertical pile capacity based on a drop hammer design. These are noted as (but not limited to):

- » AS2870 – Residential Slabs and Footings - Appendix G – Deep Footings
- » Modified Hiley Formula
- » Other methods that may be investigated for use include
 - o Modified EN formula
 - o Danish formula
 - o Janbu's formula

The formula and inputs for use of the above can be found online and in appropriate research and codified documents.

When designing using drop hammers, the design engineer is to be aware that:

- » Drop hammers dropped from heights greater than 1m are not advised due to high-energy production and limited stress capacity at the top of the FRP pile
- » The top of the FRP piles are to be protected with a block
- » Driving stresses are to be kept to a minimum
- » The toe of the pile is required to have an insert and bolt installed
- » If using splice connection, the designer is required to check the number of bolts required to prevent shear actions from the hammer energy

10.2.2 VIBRATORY/PNEUMATIC DESIGN

Vibratory hammers can be beneficial for use in remote or difficult locations. The design engineer is to take responsibility of confirming that all vibratory hammer installed piles meet their driven pile performance criteria for the project. There is evidence available that vibratory installed piles provide considerably lower geotechnical capacities than drop hammer solutions.

All vibratory hammer solutions should be confirmed with drop hammer or in-situ testing.

Testing to be undertaken using revised Hiley formula or to AS2159 Section 8 - Testing.

10.2.3 DETAILING

10.2.3.1 PILE SPLICES

For pile designs where the total embedment length of the pile is greater than the allowable or practical transportation size of the pile, there will need to be allowance for FRP splices to create additional length.

Wagners CFT produce an internal pile splice that can be used to increase the length of pile arrangements to ensure the piles are bearing on the required strata. Details of these splice arrangements are available upon request. The design engineer is to check the following items for splice design:

- » Ultimate compression load transfer through the splice and bolted connections
- » Ultimate shear action on the bolted pile splice assembly
- » Ultimate bending action on the bolted pile splice assembly
- » Estimate on the location of pile splices for the proposed structure

Pile splicing capacities are based on bolted insert connection results for the splice, and bolted 'no insert' connection results for the splice-SHS wall connection. The designer must check these values based upon the intended impact energy and ultimate compression or tension requirements of the structure.

10.2.3.2 PILE TOE

Driving of FRP piles can produce large, confined forces at the base of the pile toe if left un-reinforced.

All Wagners CFT piles are to be installed with a Wagners CFT insert block and bolt installed at the toe to prevent bursting of the pile structure due to large internal confined forces within the hollow section profile.

This creates harder driving conditions than piles installed without the toe, but will produce a better solution in the long-term.

Refer Appendix C for bolted insert capacities.

10.3 DRIVEN PILES IN SILTS AND CLAYS

FRP Piles founded in silt and clay environments are subject to further investigation of the following items in accordance with industry best practice:

- » Settlements
- » Negative skin friction
- » Liquefaction and kinematic pile design

10.4 DRIVEN PILES IN SAND

FRP Piles founded in sand environments are subject to further investigation of the following items in accordance with industry best practice:

- » Adequate bearing resistance with small influence of skin friction
- » Potential for pre-boring of piles to ensure depths can be achieved on-site
- Pre-boring may include removal of the material, or
- Disturbance of the material for easier driving
- » Settlements of single piles and group actions for differentials

10.5 PILE GROUP EFFECTS

FRP driven piles are subject to assessment of pile group effects just like any other pile material.

Wagners CFT recommend that the designer follow industry best practices for pile group effects such as Converse-labarre and Seeler-keeney to satisfy themselves that the geotechnical pile group design will be adequate for the imposed design actions.

COMPONENT DESIGN



11.1 DECKING

Decking on FRP Boardwalks and pedestrian structures can be designed and installed using Wagners CFT FRP decking. The design capacity of the FRP decking is determined based on experimental data. Extensive tests were undertaken to establish the accurate design capacities under actual/conservative loading conditions i.e. placing the test load at mid-span and adjacent to the free edge of two-span decking. The design loads are summarised in the tables presented in Appendix D. These design values are based on testing to L/120 or 6mm deflection limit, whichever is lower, as per ACMA FRP Grating Manual. The point load values in the table include 0.6 long-term combination factor (Ψ_l) as per Table C1 of AS1170.0. Moreover, the ultimate limit state capacity of the decking has been verified during testing by applying a 1.5 ULS factor to the Serviceability Design Load and includes the relevant 'kt' factor in accordance with testing requirements to AS1170.0. It is the design engineer responsibility to decide on the appropriate combination factor for their design application. Converting between combination factors is largely linear. Please contact Wagners CFT for more information.

The dimensions and design loads of the decking are detailed in Appendix D, while the connection details and capacities can be found in Appendix C-3.

11.2 RAILING

Railings on FRP Boardwalks and pedestrian structures can be designed and installed using Wagners CFT FRP sections.

The design of railings is to be undertaken using standard engineering theory for simply supported beams spanning from vertical post to vertical post carrying the appropriate handrail loading to AS/NZS 1170.1. The serviceability and ultimate limit state design of these members can be carried out in accordance with Section 4.

Railings can also be designed using Stainless Steel CHS or hardwood timber elements to AS4673 and AS1720.1 respectively.

11.3 STAIR-TREADS

FRP StairTreads are made and designed in similar manner to the FRP decking, hence have the same sectional properties and strength capacities.

STRUCTURE DESIGN



DESIGN PROCEDURE

1. Introduction

- 1.1 Typical Boardwalk Section and Elevation

2. Design Criteria

- 2.1 General
- 2.2 Permanent Action
- 2.3 Imposed Action
- 2.4 Wind Load
 - 2.4.1 Site Wind Speed
 - 2.4.2 Wind Direction Multiplier
 - 2.4.3 Terrain Height Multiplier
 - 2.4.4 Shielding Multiplier
 - 2.4.5 Topographic Multiplier
 - 2.4.6 Ultimate Limit State (ULS) Wind Design
 - 2.4.7 Serviceability Limit State (SLS) Wind Design
 - 2.4.8 Transverse Wind Load
 - 2.4.9 Vertical Wind Load
- 2.5 Earthquake Analysis
 - 2.5.1 Earthquake Design Category (EDC)
- 2.6 Forces Resulting From Water Flow
 - 2.6.1 Drag force on superstructures due to water flow
 - 2.6.2 Drag forces on piers due to water flow
 - 2.6.3 Lift force on superstructures
 - 2.6.4 Moment on a superstructure
 - 2.6.5 Forces due to debris:
 - 2.6.6 Forces due to log impact:
 - 2.6.7 Effects due to buoyancy and lift
- 2.7 Live Loads On Barriers
 - 2.7.1 Loading Criteria
 - 2.7.2 Deflection Criteria

3. Structural Analysis

- 3.1 Design Calculations
 - 3.1.1 Joists
 - 3.1.2 Bearers
 - 3.1.2.5 Natural Frequency
 - 3.1.3 Total System Analysis
 - 3.1.4 Diagonal Brace
 - 3.1.5 Handrail Posts
 - 3.1.6 Handrail System Analysis
 - 3.1.7 Columns
 - 3.1.8 Decking
 - 3.1.9 Natural Frequency

4. Connection Design

- 4.1.1 Joists to Bearers
- 4.1.2 Bearers to Piles
- 4.1.3 Diagonal Brace to Piles
- 4.1.4 Handrail Posts to Bearers

5. Foundation Design

- 5.1 Pile Design
 - 5.1.1 Pile Loading
 - 5.1.2 Design Geotechnical Strength of Driven Piles
 - 5.1.3 End Bearing Resistance
 - 5.1.4 Shaft Resistance
 - 5.1.5 Total Pile Compression Resistance
 - 5.1.6 Total Pile Tension Resistance

6. Wagners CFT WORKING DRAWINGS AND CERTIFICATION PROCESS

BOARDWALK EXAMPLE

The following example demonstrates how to utilise this design guide to design all elements of a pedestrian boardwalk. The example calculations refer to certain code references on which the calculations are based. The designer is responsible to ensure they are the current standards and codes of practice relevant to their location at the time of design.

EXAMPLE PROJECT OUTLINE:

Location:	Sometown, North Queensland
Application:	Pedestrian Boardwalk adjacent to River
Total Boardwalk Length:	xx.xx m
Typical Boardwalk Width:	2.4 m between handrails.
Grid Spacing:	4600 mm (pile to pile centre)
Handrail Height:	1200 mm
Design Life:	50 years
Importance Level:	2.0 – Normal Structures
Wind Region:	C - Cyclonic
Terrain Category:	1.0
Loading Brief:	Walking Tracks Class 3 as per AS 2156.1:2001
Natural Frequency:	Greater than 5Hz

Note: FRP Piles founded in silt and clay environments are subject to further investigation of the following items in accordance with industry best practice:

- » Settlements
- » Characteristic Strength Capacity, kN
- » Liquefaction and kinematic pile design

1.1 TYPICAL BOARDWALK SECTION AND ELEVATION

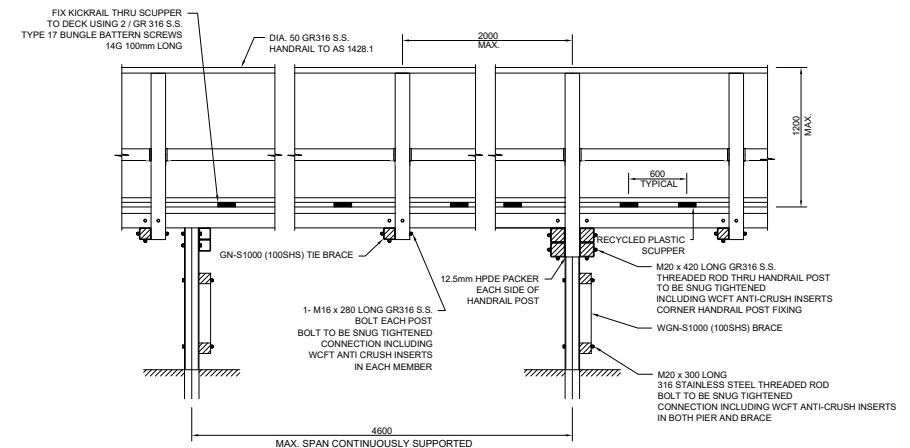
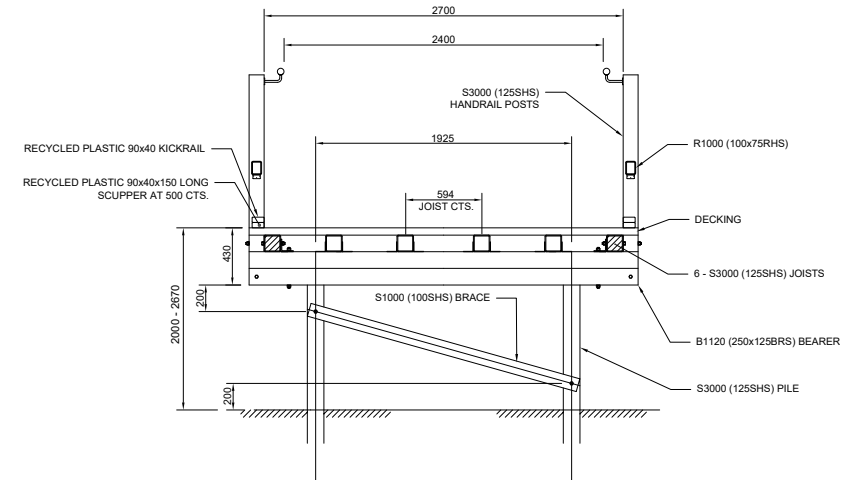

2 DESIGN CRITERIA

2.1 GENERAL

BCA/NCC:2019
Table B1.2a and b

Importance Level (IL) – 2.0 – Normal Structures
Annual Probability of Exceedance (APE) for IL 2.0 Structures
Wind (cyclonic) = 1:500
Earthquake = 1:500
Design Working Life = 50 years

2.2 PERMANENT ACTION

AS/NZ 1170.1:2002
(R2016)

Permanent action from the decking self-weight
Replas Enduroplank manufacturer's specification -> 5.8kg for 195mm x 1000mm piece
 $G = 5.8\text{kg} / (0.195\text{m} \times 1.0\text{m}) \quad [\text{kg}/(\text{m}.\text{m})]$
 $= 29.74 \text{ kg}/\text{m}^2 / (1000 / 9.81\text{m}/\text{s}^2)$
 $= 0.3\text{kPa}$

Self weight of other components is determined from the member section properties (Appendix A) plus an allowance for the weight of connection components.

$G = 0.25\text{kPa}$

$G_{\text{total}} = 0.55\text{kPa}$

2.3 IMPOSED ACTION

AS/NZS 2156.2:2001
CI 2.3(b)

Vertical $P_L = 1.4\text{kN}$ point load over 75mm x 75mm SQ
 $Q_V = 3\text{kPa}$ (track class 3 access ways) ($Q = 4.0\text{kPa}$ for viewing Platforms)

AS/NZS 2156.1
2001 Table 3

Horizontal $Q_H = 0.25 \text{ kPa}$ for platforms without seats
 $Q_H = 0.25 \times 2.5 \text{ m} = 0.63 \text{ kN/m}$

AS/NZS 1170.1:2001
CI 3.9

AS2156.2 2001
CI 2.4

Pattern Live Loads should also be assessed on a case by case basis. These can potentially govern the design, especially for foundation loading.

Note: Horizontal actions to be assessed along with vertical imposed actions in combination case.

AS/NZS 1170.2:2011
Amdt 2:2012
CI 4.2.1(a)

BCA/NCC:2019
Table B1.2a and b
AS/NZ 1170.0:2002
Table 3.1

AS/NZ 1170.2:2011
CI 2.2

AS/NZ 1170.2:2011
Table 3.1

CI 3.4(a)

AS/NZ 1170.2:2011
CI 3.3.2

AS/NZ 1170.2:2011
Table 4.1

AS/NZ 1170.2:2011
CI 4.3

2.4 WIND LOAD

Structure location – North Queensland, Australia. Within 50km of coast.

Refer figure 3.1A to find wind region = Region C

Terrain Category – 1.0 – Exposed open terrain and water for ULS and SLS

Importance Level – 2.0 – Normal Structures

Annual Probability of Exceedance (APE)

Wind – APE = 1/500

2.4.1 SITE WIND SPEED - $V_{sit,\beta}$:

$$V_{sit,\beta} = V_R \cdot M_d \cdot (M_{z,cat} \cdot M_s \cdot M_t)$$

Regional Wind Speed V_R

APE = 1/500

$V_{R,500} = 66 \times F_c$ (Ultimate Limit State, Region C)

Where $F_c = 1.05$ (For $R > 50$ years)

$$V_{R,500} = 69.3 \text{ m/s}$$

Site Wind Speed:

$$V_{sit,\beta} = V_R \cdot M_d \cdot (M_{z,cat} \cdot M_s \cdot M_t)$$

$$V_{sit,\beta} = 69.3 \times 1.0 \times (0.99 \times 1 \times 1) = 68.6 \text{ m/s}$$

2.4.2 WIND DIRECTION MULTIPLIER – M_d :

Region C – $M_d = 0.95$ (For major elements)

$M_d = 1.0$ (For decking and joists)

2.4.3 TERRAIN HEIGHT MULTIPLIER – $M_{z,CAT}$:

Structure height from ground = 2.0 – 2.6m

Terrain Category = 1.0

Structure Height ≤ 3.0 m

$$M_{z,cat} = M_{3.0,1.0} = 0.99$$

AS/NZ 1170.2:2011
CI 4.4

2.4.4 SHIELDING MULTIPLIER – M_s :

There are no buildings or large structures to provide any type of wind shielding and as such does not warrant a reduction in loading.

$$M_s = 1.0$$

AS/NZ 1170.2:2011
CI 2.4

2.4.5 TOPOGRAPHIC MULTIPLIER – M_d :

Region C – $M_d = 0.95$ (For major elements forces and bending moments)

$M_d = 1.0$ (For decking and joists)

AS/NZ 1170.2:2011
CI 2.4.1

2.4.6 ULTIMATE LIMIT STATE (ULS) WIND DESIGN:

Annual Probability of Exceedance:

APE = 1:500

Design Wind Pressure:

$$\begin{aligned} p_{ULS} &= 0.5 \cdot \rho_{air} \cdot V_{des,\theta}^2 \quad (\text{where } V_{des,\theta} = V_{sit,\beta}) \\ &= 0.5 \times 1.2 \times 68.6^2 \text{ m/s} \times 10^{-3} \\ &= 2.82 \text{ kPa} \end{aligned}$$

AS/NZ 1170.2:2011
Table 3.1

2.4.7 SERVICEABILITY LIMIT STATE (SLS) WIND DESIGN:

Annual Probability of Exceedance:

Adopt APE = 1:25 Designer to make own decision re this. Refer AS1170.0

Appendix C

Regional Wind Speed:

$$F_c = 1.0 \quad (\text{For } R < 50 \text{ years})$$

$$V_{25} = 47 \times F_c = 47 \times 1.0$$

$$V_{25} = 47 \text{ m/s}$$

AS/NZ 1170.2:2011
CI 2.2

Serviceability Wind Speed:

$$V_{sit,\beta} = V_R \cdot M_d \cdot (M_{z,cat} \cdot M_s \cdot M_t)$$

$$V_{sit,\beta} = 47 \times 1.0 \times (0.99 \times 1 \times 1) = 46.53 \text{ m/s}$$

AS/NZ 1170.2:2011
CI 2.4.1

Serviceability Wind Pressure:

$$p_{SLS} = 0.5 \cdot \rho_{air} \cdot V_{des,\theta}^2 \quad (\text{where } V_{des,\theta} = V_{sit,\beta})$$

$$p_{SLS} = 0.5 \times 1.2 \times 46.53^2 \text{ m/s} \times 10^{-3}$$

$$p_{SLS} = 1.30 \text{ kPa}$$

AS 5100.2:2017
CI 17.3
AS 5100.2:2017
CI 17.3.1(a)

Wind load design for boardwalks has been taken from AS 5100.2-2017 wind design for bridge structures.

2.4.8 TRANSVERSE WIND LOAD:

Ultimate Limit State: Wind Load on Deck:

$$W_{tu}^* = 0.6 \cdot V_u^2 \cdot A_t \cdot C_d = P_{ULS} \cdot A_t \cdot C_d$$

AS 1170.2:2011
Table E4

A_t = area of structure for calculation of wind load
 $b = 2.7\text{m}$
 $d = 1.1\text{m}$ (handrails) + 0.055m (decking) + 0.125m (joists)
 $d = 1.28\text{m}$

AS 5100.2:2017
Figure 17.3.3

$$C_d = 2.20 \quad (\text{For square section face to wind})$$

$$b/d = 2.7\text{m} / 1.28\text{m}$$

$$b/d = 2.11$$

$$C_d = 1.50 \quad (\text{For edge of deck normal to wind})$$

AS 5100.2:2017
CI 17.3.1(b)

$$W_{tu}^* = 2.82 \times 0.125 \times 2.2$$

$$= 0.78 \text{ kN/m}$$

Transverse ULS wind load to the Handrail Posts

$$W_{tu}^* = 0.62 \text{ kN/m}$$

Transverse ULS wind load to the Handrail Posts to the Handrail RHS WGN-R1000 (100x75RHS)

$$W_{tu}^* = 0.17 \text{ kN/m}$$

Transverse wind loads to the Handrail CHS (50 CHS) ($C_d = 1.2$)

$$W_{tu}^* = 2.82 \times (0.125 + 0.055) \times 1.5$$

$$= 0.76 \text{ kN/m}$$

Transverse ULS wind load to the deck structure (125 SHS + 50mm deck)

AS 5100.2:2017
CI 17.5(a)

AS 5100.2:2017
CI 17.5(b)

Serviceability Limit State:

$$W_{ts}^* = P_{SLS} \cdot A_t \cdot C_d$$
$$W_{ts}^* = 1.30 \times 0.125 \times 2.2$$
$$= 0.36 \text{ kN/m}$$

$$W_{ts}^* = 0.29 \text{ kN/m}$$

$$W_{ts}^* = 0.08 \text{ kN/m}$$

$$W_{ts}^* = 1.30 \times (0.125 + 0.055) \times 1.5$$
$$W_{ts}^* = 0.35 \text{ kN/m}$$

Transverse SLS wind load to the Handrail Posts

Transverse SLS wind load to the Handrail RHS
WGN-R1000 (100 x 75 RHS)

Transverse SLS wind load to the Handrail CHS
(50 CHS) ($C_d = 1.2$)

For the deck structure (125 SHS + 50mm deck)
For the deck structure (125 SHS + 50mm deck)

2.4.9 VERTICAL WIND LOAD:

Ultimate Limit State:

$$W_{vu}^* = P_{ULS} \cdot A_p \cdot C_L$$

Serviceability Limit State:

$$W_{vs}^* = P_{SLS} \cdot A_p \cdot C_L$$

A_p = plan area

$$C_L = 0.75$$

Uplift load on Joists

Joist load width = 0.594m

$$W_{vu}^* = 2.82 \times 0.594 \times 0.75$$

$$W_{vu}^* = 1.26 \text{ kN/m}$$

$$W_{vs}^* = 0.58 \text{ kN/m}$$

Uplift load on Bearers

Bearer load width = 5.75m (i.e. 1.25 x 4.6 for centre support of double span)

$$W_{vu}^* = 2.82 \times 5.75 \times 0.75 \quad \text{ULS vertical load}$$
$$= 12.16 \text{ kN/m}$$

$$W_{vs}^* = 5.61 \text{ kN/m} \quad \text{SLS vertical load}$$

AS 1170.4:2007

AS 1170.4:2007

Figure 2.2

BCA/NCC:2019

Table B1.2a and b

AS 1170.4:2007

Table 3.1

AS 1170.4:2007

Cl 3.2

See Table 3.2 or
Figure 3.2(F)

AS 1170.4:2007

Cl 4.1.1

AS 1170.4:2007

Table 2.1

AS 1170.4:2007

Cl 5.3

2.5 EARTHQUAKE ANALYSIS

Refer to AS 1170.4 Flow Diagram for Design Procedure

Importance Level = 2.0

Probability Factor:

APE = 1:500

$k_p = 1.0$

Hazard Factor:

$Z = 0.09$

Obtain from Geotechnical report .

For this example adopt : Soil Class C_e – Shallow Soil (predominantly sands and soft clays, soil depth < 40m)

2.5.1 EARTHQUAKE DESIGN CATEGORY (EDC):

$k_p.Z$ for site sub-soil class

$k_p.Z = 1.0 \times 0.09$

$k_p.Z = 0.09$

Importance Level = 2

Structure height < 12m

Therefore Earthquake Design Category (EDC) = I

Equivalent static lateral force for the whole structure or a component

$F_i = 0.1.W_i$

Where W_i = seismic weight of the structure at level i – see Clause 6.2.2

$W_i = \Sigma(G_i + \Psi_c Q_i)$
 $= 0.57 \text{ kPa} + 0.3 \times 3 \text{ kPa}$
 $= 1.47 \text{ kPa}$

$F_1 = 0.1 \times 1.5 \text{ kPa}$
 $= 0.15 \text{ kPa}$

Overall Deck Width = 2.95m

$F_1 = 2.95 \times 0.15 \text{ kPa}$

$F_1 = 2.95 \times 0.15 \text{ kPa}$
 $F_1 = 0.44 \text{ kN/m}$ (conservative as this considers live load on the overall width not the clear width)
 This is less than the transverse wind load so earthquake will not govern in this case.

2.6 FORCES RESULTING FROM WATER FLOW

Design criteria = Total inundation of flood waters

Assume the following for this exercise:

Mean Velocity of water flow for ultimate limit states = $V_u = 0.7 \text{ m/s}$

Flood $R_L = 9.0 \text{ m}$

Deck $R_L = 3.8 \text{ m to } 4.5 \text{ m}$

The most critical flood loads may occur before maximum flood height is achieved. AS 5100.2 states "As the critical design condition may occur at the flood level which just causes overtopping of the superstructure, an estimate of the return interval of such a flood shall be made and, if appropriate, this condition shall be considered in the design".

Ultimate Load Factor $\gamma W_F = 1.3$

γW_F may not be required if intermediate stage heights of flood levels are higher than the design flood level for a 2000 year ULS ARI.

2.6.1 DRAG FORCE ON SUPERSTRUCTURES DUE TO WATER FLOW:

Find the proximity ratio (P_r) and relative submergence (S_r). Refer to Figure 16.5.2(B).

$$P_r = y_{gs} / d_{ss} \qquad S_r = d_{wgs} / d_{sp}$$

Case 1: Fully Submerged

$$d_{wgs} = 9 - 4.5 \text{ m} = 4.5 \text{ m}$$

$$d_{sp} = d_{ss} = \text{varies} = 0.1 - 1.2 \text{ m}$$

$$y_{gs} = 2 \text{ to } 2.6 \text{ m}$$

$$S_r = 3.75$$

$$P_r = 1.67$$

Drag coefficient $C_d = 3.3$

For structure

Drag coefficient $C_d = 1.8$

For handrails

AS 5100.2:2017
Chapter 16

AS 5100.2:2017
Cl 16.5.3.1

AS 5100.2:2017
Cl 16.5.2

AS 5100.2:2017
Cl 16.5.2(B)

AS 5100.2:2017
Cl 16

$$F_{du}^* = 0.5 \cdot C_d \cdot V_u^2 \cdot A_s$$

A_s = wetted area of superstructure, including any railings or parapets, projected on a plane normal to water flow (m)

$$F_{du}^* = 0.5 \times 3.3 \times 0.7^2 \times (0.125 + 0.05) \quad \text{For the deck structure}$$
$$= 0.141 \text{ kN/m}$$
$$F_{du}^* = 0.5 \times 1.8 \times 0.7^2 \times 0.125 \quad \text{For the upright posts}$$
$$= 0.055 \text{ kN/m}$$
$$F_{du}^* = 0.044 \text{ kN/m} \quad \text{For infill handrails WGN-R1000 (100x75RHS)}$$

2.6.2 DRAG FORCES ON PIERS DUE TO WATER FLOW:

AS 5100.2:2017
Cl 16.4.1

$$F_{du}^* = 0.5 \cdot C_d \cdot V_u^2 \cdot A_d \quad \text{For guard posts and piles (125 SHS)}$$
$$C_d = 1.4 \quad \text{For square end pier nosing (i.e. SHS post)}$$
$$F_{du}^* = 0.5 \times 1.4 \times 0.7^2 \times 0.125$$
$$F_{du}^* = 0.043 \text{ kN/m}$$

2.6.3 LIFT FORCE ON SUPERSTRUCTURES:

AS 5100.2
Cl 16.5.3

$$F_{LU}^* = 0.5 \cdot C_L \cdot V_u^2 \cdot A_L$$

A_L = load width of member

- = 594mm for joists
- = 4600mm for bearers (joists in single span)
- = 4600mm x 1.25 (double span factor)
- = 5750mm for bearers (joists in double span)
- = 4600mm x 1.1 (triple span factor)
- = 5060mm for bearers (joists in triple span)

$C_L = +0.0, -0.8$
(+) denotes uplift on the structural member under consideration
(-) denotes downward force on the structural member under consideration

AS 5100.2:2017
Figure 16.5.3

Joists (+):

$$F_{LU}^* = 0.5 \times 0.0 \times 0.7^2 \times 0.594 = 0.0 \text{ kN/m}$$

Joists (-):

$$F_{LU}^* = 0.5 \times -0.8 \times 0.7^2 \times 0.594 = -0.12 \text{ kN/m}$$

Bearer (+):

$$F_{LU}^* = 0.5 \times 0.0 \times 0.7^2 \times 5.75 = 0.0 \text{ kN/m}$$

Bearer (-):

$$F_{LU}^* = 0.5 \times -0.8 \times 0.7^2 \times 5.75 = -1.13 \text{ kN/m}$$

AS 5100.2:2017

Figure 16.5.4

AS 5100.2:2017

Figure 16.5.4

Uplift and downward forces may be combined with the moment on the superstructure due to water flow as outlined in the next section.

2.6.4 MOMENT ON A SUPERSTRUCTURE:

The moment at the soffit level at the centre-line of the superstructure shall be calculated as:

$$M_{gu}^* = 0.5 \cdot C_m \cdot V_u^2 \cdot A_s \cdot d_{sp}$$

C_m is obtained from Figure 15.4.4. where $Sr = 3.75$ and $Pr = 1.67$

$$C_m = 5.0$$

$$d_{sp} = 1.2\text{m}$$

$$A_s = 1.2\text{m} \quad (\text{the potentially blocked handrail height will become a loaded area})$$

$$M_{gu}^* = 0.5 \times 5.0 \times 0.7^2 \times 1.2 \times 1.2$$

$$M_{gu}^* = 1.72 \text{ kNm/m} \quad (\text{this is the moment per meter load width of the structure})$$

Load width = 4.6m

$$M_{gu}^* = 1.72 \text{ kNm/m} \times 4.6\text{m} = 8.11 \text{ kNm per bearer/pile location.}$$

Additional Axial Load on Piles:

$$F^* = M/d$$

$$F^* = 8.11\text{kNm} / 1.93\text{m}$$

$$F^* = 4.2 \text{ kN couple force}$$

Refer Typical Walkway Section D

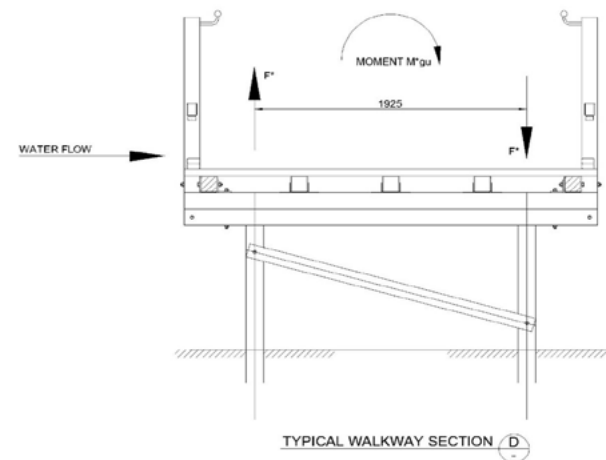

Additional Shear Load on Joists:

$$F^* = M/d$$

$$F^* = 8.11 \text{ kNm} / (2.7\text{m} - 0.125\text{m})$$

$$F^* = 3.15 \text{ kN couple force}$$

Refer Typical Walkway Section E

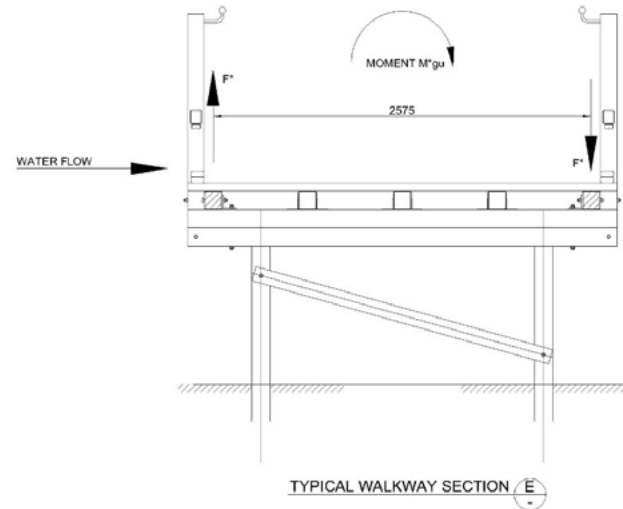

2.6.5 FORCES DUE TO DEBRIS:

For this example adopt the ultimate flood level height as 4.5m above deck RL. Debris loading in this situation is negligible due to debris matter (plants, tree's etc) floating to the surface of the flood waters and over the top of the boardwalk. Consideration is still required to apply debris loading to all structures as the flood levels increase over the deck RL. It is in these situations where a debris mat may cause the most adverse loading effect on the structure.

For the purpose of this example we apply a debris mat of 1.2m. This is at the discretion of the designer.

$$F_{du}^* = 0.5 \cdot C_d \cdot V_u^2 \cdot A_{deb}$$

$$F = V / (g \cdot y)^{0.5}$$

$$y = y_{gs}$$

$$F = 0.7 / (9.81 \times 1.7)^{0.5}$$

$$F = 0.17; Pr = 1.42$$

$$C_d = 5.6$$

$$F_{du}^* = 0.5 \times 5.6 \times 0.7^2 \times 1.2$$

$$F_{du}^* = 1.65 \text{ kN/m}$$

AS 5100.2:2017

CI 16.6.4

AS 5100.2:2017

Figure 16.6.4 (B)

AS 5100.2:2017
CI 16.7.2

Kinetic Energy
Equation

AS 5100.2:2017
CI 16.8

Archimedes'
Principle

2.6.6 FORCES DUE TO LOG IMPACT:

As discussed in the debris section of this guide, log impact loads may be applicable during the flooding stage before ultimate flood height is achieved. To design for FRP use the following data from AS 5100.2-2017.4. Surface impacts shall incorporate 1.4 factor on average velocity as determined by the design engineer:

Hollow Concrete Piers – stopping distance = 150mm (d)
Log mass = 2000kg (m)

$$\begin{aligned} \text{Energy } E &= 0.5 \cdot m \cdot v^2 & [J = \text{kg} \cdot \text{m}^2/\text{s}^2 = \text{N} \cdot \text{m}] \\ &= 0.5 \times 2000 \times 0.7^2 \\ &= 490 \text{ J} \end{aligned}$$

$$\begin{aligned} F &= E/d \\ F &= 490 \text{ N} \cdot \text{m} / 0.15 \text{ m} \\ F &= 3.3 \text{ kN} \quad \text{log impact load in } 0.7\text{m/s flow stopping within } 150\text{mm} \end{aligned}$$

2.6.7 EFFECTS DUE TO BUOYANCY AND LIFT:

Water Density = $\rho_w = 1000\text{kg/m}^3$

Volume of air per WGN-S3000 (125SHS) member

$$V = 0.125 \times 0.125 \times 1 = 0.016\text{m}^2/\text{m}$$

$$\begin{aligned} B^* &= \rho_w \cdot V \cdot g \\ B^* &= 1000 \times 0.016 \times 9.81 \times 10^{-3} & [(\text{kg}/\text{m}^3) \cdot (\text{m}^2/\text{m}) \cdot (\text{m}/\text{s}^2) = \text{N}] \\ B^* &= 0.16 \text{ kN/m} \end{aligned}$$

Example of using the buoyancy equation to design for uplift. Look at one section of boardwalk at the pile/bearer interface:
5 joists, 2 bearers, 2 piers, 6 posts for handrails, 2 hand rails each side.

$$\begin{aligned} \text{Total Length} &= (5 \times 4.6\text{m}) + (2 \times 2.8\text{m}) + (2 \times 2.6\text{m}) + (6 \times 1.4\text{m}) + (2 \times 2 \times 4.6\text{m}) \\ \text{Total Length} &= 60.6 \text{ m} \end{aligned}$$

$$\begin{aligned} B^* &= 0.16 \text{ kN/m} \times 60.6 \text{ m} \\ B^* &= 9.7 \text{ kN uplift force at pile/bearer interface} \end{aligned}$$

Tie down is required to hold down 9.7 kN of uplift force due to buoyancy during a Q100 flood event per pile/bearer interface.

AS 5100.2
CI 16.8

Buoyancy and lift forces are to be applied concurrently with other water flow forces. These include:

- » Drag forces (CI 16.5.2)
- » Lift forces (CI 16.5.3)
- » Moment on superstructure (CI 16.5.4)
- » Debris forces (CI 16.6.4)

An example of one of these load cases might be:

$$\begin{aligned} &= 1.0 \text{ Moment on superstructure} + 1.0 \text{ Buoyancy (at pile)} \\ &= 4.2 \text{ kN} + 9.7 \text{ kN} / 2 \\ &= 9.05 \text{ kN [axial tension on pile]} \end{aligned}$$

2.7 LIVE LOADS ON BARRIERS:

Barrier loading is based upon the values set out in AS 2156.2:2001 Table 1. AS 5100.2:2017 barrier loads are seen as quite conservative for structures that will not be attracting crowd loading.

For this example adopt a class 3 “access structure” and not a “platform”. Therefore the below values can be used as live loads on barriers.

2.7.1 LOADING CRITERIA:

Top rail Horizontal = 0.36 kN/m
Top rail Vertical = 0.36 kN/m
Infill Horizontal = 0.75 kPa
Infill Any Direction = 0.25 kN

2.7.2 DEFLECTION CRITERIA:

Handrails - $H/60 + L/240$ (horizontal midspan system deflection) at applied action Q.

Deflection criteria for handrails and posts are based upon AS/NZS 1170.1:2002 Supplement 1 and AS/NZS 1170.0:2002 Amdt-3 Table C1. Again, deflection criteria laid out in AS 5100.2:2004 for pedestrian handrails is seen as conservative and financially inefficient for the type of structures that Wagners CFT construct. This is mainly due to the lower elastic modulus for FRP compared to steel.

AS 5100.2:2017 AS
2156.2:2001
CI 2.7

AS 2156.2:2001
Table 1

AS/NZS 1170.1:2002
Supplement 1
CI C3.6

3 STRUCTURAL ANALYSIS

A lot of pedestrian boardwalk structures with predominantly single spans and where there are no significant lateral loads, e.g. from stream flow or debris loading, can be designed by hand calculation. In this example manual calculations are used for demonstration purposes for the joist, bearer and handrails. A frame analysis using the program Microstran was carried out and the results of that are used to determine the internal forces in the columns (or posts), piles and bracing. The use of a computer analysis method does provide a better insight into the performance of the structure as a whole, and also per member. It is easy to look at strength design data and serviceability design data and compare each of these areas to the limiting criteria. It is also simple to take account of shear distortion deflections in members by inputting the section property shear areas as well as the gross area of the sections. From there it is a simple design check procedure to confirm that each member is performing adequately.

The following sections demonstrate the calculations required to assess the design capacity of Wagners CFT sections to resist the design action affect.

This is represented by:

$$S^* \leq \Phi R_u$$

This method is used to assess joists, bearers, system deflection and handrail loading of the structure.

FRP design is often governed by deflection criteria due to the low elastic modulus of the material. The minimum deflection criteria should be $\text{Span}/250$ for $G + \Psi_c Q$ (where $\Psi_c = 0.6$). Very rarely will a member fail at its ultimate capacity if serviceability criteria is assessed. In saying this, both cases are to be thoroughly examined on each design.

Wagners CFT Design Guide applies three strength reduction factors to all of the FRP design calculations depending on application of the element under consideration. These are :

- » Time effect factor, λ
- » Adjustment Factor for end use, $C (= C_M \times C_T \times C_{CH})$
- » Capacity Reduction Factor, ϕ

For serviceability deflection calculations a deflection amplification factor $K_{cr}(t)$ is applied depending on the duration of the loading.

In this example the following reduction factors have been adopted.

Time Effect Factor λ

"The time effect factor accounts for the creep-rupture phenomenon of pultruded FRP structural elements under sustained load." The strength reduction factor which affects the design resistance varies with the load case considered which is the design action.

$\lambda = 0.8$ is applied for short term or transient loading cases such as full imposed loads or wind, earthquake or water loading. (e.g. $1.2G + 1.5 Q, 0.9G + Wu$)

$\lambda = 0.4$ is applied for load cases which reflect permanent, long term or sustained loading. (e.g. $1.35G$)

Adjustment Factor for End Use Environment C

$$C = C_T \cdot C_M \cdot C_{CH}$$

C_T = Temperature Factor

Looking at AS5100.2, an average bridge temperature can be calculated and used to assess the required reduction factor on FRP elements using The Wagners CFT Design Guide.

Shade Air Temperatures for Coastal Areas (<1000m above sea level) North of the 22nd parallel.

$$\text{Max.} = 44^\circ\text{C}$$

$$\text{Min.} = 4^\circ\text{C}$$

Average Bridge Temperatures

$$\text{Max.} = 48^\circ\text{C}$$

$$\text{Min.} = 6^\circ\text{C}$$

Using the calculations provided for Vinyl Ester material in Wagners CFT Design Guide Section 3.5.3 :

$$\text{For Strength, } C_T = 1.444 - 0.0144 \times 48 = 0.753$$

$$\text{For Modulus of Elasticity, } C_T = 1.308 - 0.0108 \times 48 = 0.79$$

C_M = Moisture Condition Factor

For this example in North Queensland assume average relative humidity is > 60% With this information the following factors need to be applied:

$$\text{For Strength, } C_M = 0.85$$

$$\text{For Modulus of Elasticity, } C_M = 0.95$$

C_{CH} = Chemical Environmental Factor

For this example assume a non-aggressive chemical environment and therefore use $C_{CH} = 1$

Therefore, for this example, the end use adjustment factor $C = 0.79 \times 0.95 \times 1.0 = 0.75$ for deflections

$$C = 0.753 \times 0.85 \times 1.0 = 0.64 \text{ for strength}$$

Deflection Amplification Factor $K_{cr}(t)$

Given that the governing load combination in this example is a heavily loaded platform or over-crowd scenario, it can be assumed that this live load duration is in the realm of 5 seconds to 5 days or a $K_{cr}(t)$ factor of 1.00 to 1.06 respectively. Conservatively, we can assume $K_{cr}(t) = 1.017$ for short term deflection of 60 minutes using equation 2.6-2. Crowd-loading is unlikely to be longer than this.

Long term deflection $K_{cr}(t)$ values would apply to permanent loading like the structure self-weight or dead load. Since the design life in this example is 50 years, $K_{cr}(t) = 1.44$ for long term deflection.

Load case combinations that these two amplification factors apply to:

Short term deflection: $\Delta st. K_{cr}(t) = 1.017 \times \Delta st$

Long term deflection: $\Delta lt. K_{cr}(t) = 1.440 \times \Delta lt$

3.1 DESIGN CALCULATIONS

3.1.1 JOISTS:

WGN-S3000 (125SHS)

Double span. It can be seen from the boardwalk elevation in Section 1.1 that the double spans aren't equal due to the centre support bearer being a single bearer connected to one side of the column. The unequal spans are 4600/4350. This example uses an average span of 4475mm. It needs to be checked if that is conservative for the span positive and negative moments.

$I_x = I_y = 6.89e6 \text{ mm}^4$

Weight = 5.94 kg/m

Joist – Vertical Load Cases:

LOAD CASE	LIMIT STATE	LOAD CALCULATION	LOAD
LC1: 1.35 G	ULS	$= 1.35 \times (.3 \times 0.594 + 0.058)$	0.32 kN/m
LC2: 1.2G + 1.5Q	ULS	$= (1.2 \times 0.3 + 1.5 \times 3) \times 0.594 + 1.2 \times 0.058$	2.96 kN/m
LC3: G + ψ .Q	SLS	$= (0.3 + 0.6 \times 3.0) \times 0.594 + 0.058$	1.30 kN/m
LC4: Water Uplift	ULS	$= (0.5 \times 0.0 \times 0.72) \times 0.594$	0.0 kN/m
LC5: Water Downward	ULS	$= (0.5 \times -0.8 \times 0.72) \times 0.594$	-0.17 kN/m
LC6: 0.9G – Wind Up	ULS	$= (0.9 \times 0.3 - 2.33 \times 0.75) \times 0.594 + 0.058 \times 0.9$	-0.64 kN/m
LC7: 0.9G – Wind Up	SLS	$= (0.9 \times 0.3 - 1.30 \times 0.75) \times 0.594 + 0.058 \times 0.9$	-0.37 kN/m
LC8: 1.2G + Wind Down	ULS	$= (1.2 \times 0.3 + 2.33 \times 0.75) \times 0.594 + 1.2 \times 0.058$	1.32 kN/m
LC9: G + Wind Down	SLS	$= (0.3 + 1.30 \times 0.75) \times 0.594 + 0.058$	0.82 kN/m

NB: Pattern live load effects shall also be considered for multiple span configurations.

Note that for short term loading the Lambda factor varies with load combination and it might not be obvious which case will govern so all.

3.1.1.1 JOIST - ULTIMATE LIMIT STATE DESIGN

For **long term loading (LC1)** the moments and shear are calculated as follows:

Maximum long term moments on double span joist:

$$\begin{aligned}M_{(+ve)}^* &= 0.07 \cdot w \cdot L^2 \\ &= 0.07 \times 0.32 \times 4.475^2 = 0.45 \text{ kNm}\end{aligned}$$

$$\begin{aligned}M_{(-ve)}^* &= -0.125 \cdot w \cdot L^2 \\ &= -0.125 \times 0.32 \times 4.475^2 = -0.80 \text{ kNm}\end{aligned}$$

Maximum long term shear on double span joist:

$$\begin{aligned}V_{\max}^* &= 0.625 \cdot w \cdot L \text{ (0.625 rather than 0.5 due to two span continuity)} \\ &= 0.625 \times 0.32 \times 4.475 = 0.9 \text{ kN}\end{aligned}$$

Maximum long term bearing on double span joist:

Note at the centre support of the two span continuous joists is a single bearer so the bearing force is the support reaction equals:

$$R^* = 0.9 \times 2 = 1.8 \text{ kN}$$

Moment Design Capacity of WGN-S3000 (125SHS) for long term loading:

$$\Phi M_b = \lambda \cdot C \cdot \Phi M_{ob}$$

where $\Phi M_{ob} = \min(\Phi M_s, \Phi M_b)$

$\lambda = 0.4$ Time effect factor

$C = 0.64$ Adjustment factor for end use

From Wagners CFT Design Guide table B-1 the reference section moment capacity $\Phi M_{os} = 33.85 \text{ kNm}$

From Wagners CFT Design Guide table B-2 the reference member moment capacities $= \Phi M_{ob+} = \Phi M_{ob-} = 33.85 \text{ kNm}$

$$\Phi M_b = \lambda \cdot C \cdot \Phi M_{ob} = 0.4 \times 0.64 \times 33.85 = 8.66 \text{ kNm} > 0.45 \quad \checkmark \quad \text{OK}$$

Shear Design Capacity of WGN-S3000 (125SHS) SHS for long term loading:

$$\Phi V_u = \lambda.C\Phi V_{0x}$$

$\lambda = 0.4$ Time effect factor
 $C = 0.64$ Adjustment factor for end use

From Wagners CFT Design Guide table B-1 the reference shear capacity
 $\Phi V_{0s} = 77.05 \text{ kN}$

$$\Phi V_u = \lambda.C\Phi V_{0s} = 0.4 \times 0.64 \times 77.05 = 19.72 \text{ kN} > 0.9 \text{ kN} \quad \checkmark \quad \text{OK}$$

Bearing Design Capacity of WGN-S3000 (125SHS) for long term loading:

$$\Phi R_u = \lambda.C\Phi R_{0x}$$

$\lambda = 0.4$ Time effect factor
 $C = 0.64$ Adjustment factor for end use

From Wagners CFT Design Guide table B.7 the reference bearing capacity
 $\Phi R_{0s} = 19.91 \text{ kN}$

$$\Phi R_u = \lambda.C\Phi R_{0s} = 0.4 \times 0.64 \times 19.91 = 5.097 \text{ kN} < 1.8 \text{ kN} \quad \checkmark \quad \text{OK}$$

Note that unreinforced CFT sections generally don't have high bearing strength hence, surfaces and support locations are required to be checked for capacity. This is especially applicable to high point load designs such as vehicles. This may apply to the supporting bearer as well.

For **short term loading** the maximum load is from LC2. Moments and shears are calculated as follows:

Maximum short moments on double span joist:

$$M_{(+ve)}^* = 0.07.w.L^2$$

$$M_{(+ve)}^* = 0.07 \times 2.96 \times 4.475^2 = 4.15 \text{ kNm}$$

$$M_{(-ve)}^* = -0.125.w.L^2$$

$$M_{(-ve)}^* = -0.125 \times 2.96 \times 4.475^2 = -7.41 \text{ kNm}$$

Maximum short shear on double span joist:

$$V_{\max}^* = 0.625.w.L$$

$$= 0.625 \times 2.96 \times 4.475 = 8.3 \text{ kN}$$

Wagners CFT
Design Guide:
Section 4.4

Wagners CFT
Design Guide:
Section 4.6

Wagners CFT
Design Guide
Sections 3.2 and 3.5

Maximum short term bearing on double span joist:

Note at the centre support of the two span continuous joists is a single bearer so the short term bearing force is the support reaction equals:

$$R^* = 8.3 \times 2 = 16.6 \text{ kN}$$

Design Moment Capacity of WGN-S3000 (125 SHS) for short term loading:

$$\Phi M_b = \lambda.C\Phi M_{ob}$$

$$\text{where } \Phi M_{ob} = \min(\Phi M_s, \Phi M_b)$$

$$\lambda = 0.8 \quad \text{Time effect factor}$$

$$C = 0.64 \quad \text{Adjustment factor for end use}$$

From Wagners CFT Design Guide table B-1 the reference section moment capacity $\Phi M_{os} = 33.85 \text{ kNm}$

From Wagners CFT Design Guide table B-2 the reference member moment capacities = $\Phi M_{ob+} = \Phi M_{ob-} = 33.85 \text{ kNm}$

$$\Phi M_b = \lambda.C\Phi M_{ob} = 0.8 \times 0.64 \times 33.85 = 17.33 \text{ kNm} > 7.41 \text{ kNm} \quad \checkmark \quad \text{OK}$$

Design Shear Capacity of WGN-S3000 (125 SHS) for short term loading:

$$\Phi V_u = \lambda.C\Phi V_{ox}$$

$$\lambda = 0.8 \quad \text{Time effect factor}$$

$$C = 0.64 \quad \text{Adjustment factor for end use}$$

From Wagners CFT Design Guide table B-1 the reference shear capacity

$$\Phi V_{os} = 77.05 \text{ kN}$$

$$\Phi V_u = \lambda.C\Phi V_{os} = 0.8 \times 0.64 \times 77.05 = 39.44 \text{ kN} > 8.3 \text{ kN} \quad \checkmark \quad \text{OK}$$

Bearing Design Capacity of WGN-S3000 (125 SHS) for short term loading:

$$\Phi R_u = \lambda.C\Phi R_{ox}$$

$$\lambda = 0.8 \quad \text{Time effect factor}$$

$$C = 0.64 \quad \text{Adjustment factor for end use}$$

From Wagners CFT Design Guide table B-7 the reference bearing capacity

$$\Phi R_{0s} = 19.91 \text{ kN}$$

$$\Phi R_u = \lambda.C\Phi R_{0s} = 0.8 \times 0.64 \times 19.91 = 10.19 \text{ kN} < 16.6 \text{ kN} \quad \text{NOT OK, inserts to be added}$$

$$\Phi R_{0s} = 66.42 \text{ kN} \quad \text{With anti-crush insert (Hole Horizontal), Table B-7}$$

$$\Phi R_u = \lambda.C\Phi R_{0s} = 0.8 \times 0.64 \times 66.42 = 34 \text{ kN} > 16.6 \text{ kN} \quad \checkmark \quad \text{OK}$$

Note that unreinforced CFT sections generally don't have high bearing strength hence inserts are to be specified at all bearing surfaces. This will apply to the supporting bearer as well.

Combined Actions

The joists may have some axial forces due to vehicle braking forces in some instances and perhaps biaxial bending in some instances. In this example we will take axial forces and Y axis bending as being insignificant and therefore the only combined action to check is bending and shear.

$$(M^*/\Phi M_u)^2 + (V^*/\Phi V_u)^2 \leq 1.0$$

Where ΦM_u is the minimum of ΦM_s and ΦM_b

For the short term load case, the equation equals:

$$(7.41/17.33)^2 + (8.3/39.44)^2 = 0.22 < 1.0 \quad \checkmark \quad \text{OK}$$

For the long term load case, the equation equals:

$$(0.8/8.66)^2 + (0.9/19.7)^2 = 0.011 < 1.0 \quad \checkmark \quad \text{OK}$$

3.1.1.2 SERVICEABILITY LIMIT STATE DESIGN

The governing SLS load case from the table above is LC3.

For CFT members deflections due to shear distortions can be significant and need to be calculated. That is the component of deflection from shear distortion (Timoshenko theory) as well as the component from flexural bending with plane sections remaining plane (Bernoulli theory).

As design charts and formula for shear distortion deflection of two span beams is scarce, and some continuous beam or frame analysis software do not cater for shear deformation deflections, first calculate simple span deflections to determine the proportion of the total deflection due to shear deformation and conservatively apply that proportion to the two span beam.

Maximum deflection of single span joist:

$$\Delta_{\text{single span}} = (K_{cr}(t)/C) \times k_1 \times (wL^4/EI) + k_2(wL^2/GA_{\text{web}})$$

where $K_{cr}(t)$ is the duration dependent deflection multiplier for creep

C is the end use factor

$k_1 = .013$ the coefficient for flexural deflection

$k_2 = .125$ the coefficient for shear distortion deflection

For short term loading G+ΨQ

$$K_{cr}(t)/C = 1.017/.75 = 1.35$$

$$w = (0.3 + 0.6 \times 3) \times .594 + .058$$

$$= 1.31 \text{ kN/m}$$

$$\begin{aligned} \Delta_{\text{single span}} &= 1.35 \times (.013 \times 1.31 \times 4475^4 / (36300 \times 6.89 \times 10^6)) + 0.125 \times 1.31 \times 4475^2 / (4280 \times 1344) \\ &= 37.63 \text{ mm} = \text{Span}/119 \text{ however this is for a simple span.} \end{aligned}$$

The component of deflection due to shear distortion in this case is

$$0.57/37.63 = 0.015$$

UDL across two spans

$$\Delta_{\text{two span}} = 1.35 \times (.0052 \times 1.31 \times 4475^4 / (35400 \times 6.89 \times 10^6)) \times 1.015$$

$$= 14.96 = \text{Span}/300 < \text{Span}/250 \quad \checkmark \quad \text{OK}$$

For long term loading G only

$$K_{cr}(t)/C = 1.44/.75 = 1.92$$

$$w = 0.3 \times .594 + .058$$

$$= 0.236 \text{ kN/m}$$

$$\Delta_{\text{two span}} = 1.92 \times (.0052 \times 0.236 \times 4475^4 / (36300 \times 6.89 \times 10^6)) \times 1.015$$

$$= 3.83 \text{ mm} = \text{Span}/1166 < \text{Span}/250 \quad \checkmark \quad \text{OK}$$

Natural Frequency:

$$f_n = 0.18 \times (g/\Delta)^{0.5}$$

where: g is acceleration, taken as 9.81 m/s^2

Δ is the instantaneous max span deflection for the appropriate joist configuration (m)

$$\Delta_{\text{two span}} = 0.0052 \times (wL^4/EI) \times 1.015 \text{ (for this example only as shear distortions have been shown to be small)}$$

w is the unit weight per meter including joists and decking (kN/m)

L is the clear span of the member (m) E is the material modulus (kPa)

I is the second moment area (m^4)

$$w_{\text{(joists)}} = 5.94 \text{ kg/m} = 0.058 \text{ kN/m}$$

$$w_{\text{(decking)}} = .3 \text{ kPa} \times .594 \text{ m} = 0.178 \text{ kN/m}$$

$$w_{\text{(total)}} = 0.236 \text{ kN/m}$$

$$E = 36300 \text{ MPa}$$

$$I_{\text{(S3000)}} = 6.89 \text{e-6 m}^4$$

$$L = 4.475 \text{ m}$$

Based on **double span** deflection criteria:

$$\Delta_{\text{single span}} = (.013 \times 0.236 \times 4475^4 / (36300 \times 6.89 \text{e}6)) \times 1.015 = 5.00 \text{ mm}$$

$$\Delta_{\text{two span}} = 0.0052 \times (0.236 \times 4475^4 / (36300 \times 6.89 \text{e}6)) \times 1.015 = 2.00 \text{ mm}$$

$$f_{n, \text{single span}} = 0.18 \times (9.81 / (5 / 1000))^{0.5} = 7.97 \text{ Hz} > 5 \text{ Hz}$$

$$f_{n, \text{single span}} = 7.98 \text{ Hz (Frequency solution from Spacegass for a double span beam)} > 5 \text{ Hz} \quad \checkmark \quad \text{OK}$$

Allowance for live load contribution can be added at design engineers discretion. Refer to AISC DG11 for recommendations on live loads applications for frequency analysis.

3.1.2 BEARERS:

Note that the bearers between the columns at the support of the 2 span continuous joist is a single WGN-B1120 (250 x 125 BRS) whereas at the abutting joist ends there is a double bearer. The single bearer case will therefore govern and that is the bearer checked in this example.

WGN-B1120 (250 x 125 BRS)

Span = 1925 mm (centreline to centreline of WGN-S3000 (125SHS) piles from drawings)

Overhang = 513 mm

Load width 4475 mm x 1.25 = 5594 mm (joists in double span configuration)

$I_x = 37.51 \text{e}6 \text{ mm}^4$

$I_y = 13.96 \text{e}6 \text{ mm}^4$

Self Weight = 11.88 kg/m = 0.117kN/m

For simplicity of analysis assume UDL load rather than joist point loads. This assumption needs to be checked to ensure it is not unconservative.

In this case will ignore the benefit of the end cantilevers.

Decking + Joist weight = 0.3 kPa + 0.117 kN/m / 0.056m = 0.51 kPa

LOAD CASE	LIMIT STATE	LOAD CALCULATION	LOAD
LC1: 1.35 G	ULS	$= 1.35 \times (0.3 \times 5.594 + 0.117)$	2.42 kN/m
LC2: 1.2G + 1.5Q	ULS	$= (1.2 \times 0.3 + 1.5 \times 3) \times 5.594 + 1.2 \times 0.117$	27.3 kN/m
LC3: G + ψ .Q	SLS	$= (0.3 + 0.6 \times 3.0) \times 5.594 + 0.117$	11.86 kN/m
LC4: Water Uplift	ULS	$= (0.3 \times 0.0 \times 0.7^2) \times 5.594$	0.0 kN/m
LC5: Water Downward	ULS	$= (0.3 \times -0.8 \times 0.7^2) \times 5.594$	-0.66 kN/m
LC6: 0.9G – Wind Up	ULS	$= (0.9 \times 0.3 - 2.33 \times 0.75) \times 5.594 + 0.9 \times 0.117$	-8.16 kN/m
LC7: 0.9G – Wind Up	SLS	$= (0.9 \times 0.3 - 1.30 \times 0.75) \times 5.594 + 0.9 \times 0.117$	-3.84 kN/m
LC8: 1.2G + Wind Down	ULS	$= (1.2 \times 0.3 + 2.33 \times 0.75) \times 5.594 + 1.2 \times 0.117$	11.93 kN/m
LC9: G + Wind Down	SLS	$= (0.3 + 1.30 \times 0.75) \times 5.594 + 0.117$	7.25 kN/m

3.1.2.1 BEARERS - ULTIMATE LIMIT STATE DESIGN:

For **long term loading (LC1)** the moment and shear forces are calculated as follows:

Maximum long term moments on span ignoring the end cantilevers:

$$\begin{aligned}M_{(+ve)}^* &= .125.w.L^2 \\ &= .125 \times 2.42 \times 1.925^2 = 1.12 \text{ kNm}\end{aligned}$$

Maximum long term shear on span:

$$\begin{aligned}V_{\max}^* &= 0.5.w.L \\ &= 0.5 \times 2.42 \times 1.925 = 2.4 \text{ kN}\end{aligned}$$

Maximum long-term bearing on bearer.:

Note the bearer ends are bolted on the side of the columns so the only bearing surfaces to check are where the bearers support the joists.

From the joist calculations, the centre support to the two span continuous joists is a single WGN-B1120 (250 x 125 BRS) bearer so the long-term bearing force is the support reaction equals:

$$R^* = 2.4 \text{ kN}$$

Moment Design Capacity of WGN-B1120 (250 x 125 BRS) bearer for long term loading:

$$\begin{aligned}\Phi M_b &= \lambda.C\Phi M_{ob} \\ \text{where } \Phi M_{ob} &= \min(\Phi M_s, \Phi M_b)\end{aligned}$$

$$\begin{aligned}\lambda &= 0.4 && \text{Time effect factor} \\ C &= 0.64 && \text{Adjustment factor for end use}\end{aligned}$$

From Wagners CFT Design Guide table B-1 the reference section moment capacity $\Phi M_{os} = 71.46 \text{ kNm}$

From Wagners CFT Design Guide table B-2 the reference member moment capacities $= \Phi M_{ob+} = \Phi M_{ob-} = 71.46 \text{ kNm}$

$$\Phi M_b = \lambda.C\Phi M_{ob} = 0.4 \times 0.64 \times 71.46 = 18.29 \text{ kNm} > 1.12 \quad \checkmark \quad \text{OK}$$

Wagners CFT
Design Guide
Section 4.2

Wagners CFT
Design Guide
Section 4.3

Shear Design Capacity of WGN-B1120 (250x125 BRS) bearer for long term loading:

$$\Phi V_u = \lambda.C\Phi V_{0x}$$

$\lambda = 0.4$ Time effect factor
 $C = 0.64$ Adjustment factor for end use

From Wagners CFT Design Guide table B-1 the reference shear capacity
 $\Phi V_{0s} = 154.1 \text{ kN}$

$$\Phi V_u = \lambda.C\Phi V_{0s} = 0.4 \times 0.64 \times 154.1 = 39.45 \text{ kN} > 2.4 \text{ kN} \quad \checkmark \quad \text{OK}$$

Design Bearing Capacity of WGN-B1120 (250x125 BRS) bearer for long term loading:

$$\Phi R_u = \lambda.C\Phi R_{0x}$$

$\lambda = 0.4$ Time effect factor
 $C = 0.64$ Adjustment factor for end use

From Wagners CFT Design Guide table B-7 the reference bearing capacity
 $\Phi R_{0s} = 19.91 \text{ kN}$ (note that this is the same as for WGN-S3000 (125SHS))

$$\Phi R_u = \lambda.C\Phi R_{0s} = 0.4 \times 0.64 \times 19.91 = 5.1 \text{ kN} > 2.4 \text{ kN} \quad \checkmark \quad \text{OK}$$

Note that unreinforced CFT sections generally don't have high bearing strength hence inserts are to be specified at all bearing surfaces. This will apply to the supporting bearer as well.

Design Axial Compressive Capacity of WGN-B1120 (250x125 BRS) bearer long term loading:

$$\Phi N_{uc} = \lambda C \Phi N_0$$

$\lambda = 0.4$ Time effect factor
 $C = 0.64$ Adjustment factor for end use
 $L_{\text{eff,Cx}} = 594 \text{ mm}$ Effective Length for compression x axis buckling
 $L_{\text{eff,Cy}} = 1925 \text{ mm}$ Effective Length for compression y axis buckling

From Wagners CFT Design Guide table B-1 the reference section compression capacity $\Phi N_{oc} = 614.76 \text{ kN}$

From Wagners CFT Design Guide table B-3 the reference member compression capacity $\Phi N_{ocx} = 614.76 \text{ kN}$

From Wagners CFT Design Guide table B-5 the reference member compression capacity $\Phi N_{ocy} = 614.76 \text{ kN}$

$$\Phi N_{uc} = 0.4 \times 0.64 \times 614.76 = 157.4 \text{ kN} > N_c^* \quad \checkmark \quad \text{OK}$$

For short term loading the maximum load is from LC2. Moment, shear and bearing are calculated as follows:

Maximum short term moments on span ignoring end cantilevers:

$$M_{(+ve)}^* = .125.w.L^2$$
$$M_{(+ve)}^* = .125 \times 27.3 \times 1.925^2 = 12.64 \text{ kNm}$$

Maximum short term shear on span:

$$V_{max}^* = 0.5.w.L$$
$$= 0.5 \times 27.3 \times 1.925 = 26.27 \text{ kN}$$

Maximum short term bearing on bearer.:

Note the bearer end connections are bolted on the side of the columns so the only bearing surfaces to check are where the bearers support the joists.

From the joist calculations centre support to the two span continuous joist is a single WGN-B1120 (250 x 125 BRS) bearer so the bearing force is the support reaction equals:

$$R^* = 13.2 \times 2 = 26.4 \text{ kN}$$

Design Moment Capacity of WGN-B1120 (250 x 125 BRS) bearer for short term loading:

$$\Phi M_b = \lambda.C\Phi M_{ob}$$

$$\text{where } \Phi M_{ob} = \min(\Phi M_s, \Phi M_b)$$

$$\lambda = 0.8 \quad \text{Time effect factor}$$

$$C = 0.64 \quad \text{Adjustment factor for end use}$$

From Wagners CFT Design Guide table C.1 the reference section moment capacity $\Phi M_{os} = 71.46 \text{ kNm}$

From Wagners CFT Design Guide table C.4 the reference member moment capacities $= \Phi M_{ob+} = \Phi M_{ob-} = 71.46 \text{ kNm}$

$$\Phi M_b = \lambda.C\Phi M_{ob} = 0.8 \times 0.64 \times 71.46 = 36.59 \text{ kNm} > 12.64 \quad \checkmark \quad \text{OK}$$

Wagners CFT
Design Guide
Section 4.2

Wagners CFT
Design Guide
Section 4.3

Design Shear Capacity of WGN-B1120 (250 x 125BRS) bearer for short term loading:

$$\Phi V_u = \lambda \cdot C \Phi V_{0x}$$

$$\lambda = 0.8$$

Time effect factor

$$C = 0.64$$

Adjustment factor for end use

From Wagners CFT Design Guide table B-1 the reference shear capacity

$$\Phi V_{0s} = 154.1 \text{ kN}$$

$$\Phi V_u = \lambda \cdot C \Phi V_{0s} = 0.8 \times 0.64 \times 154.1 = 78.90 \text{ kN} > 26.27 \text{ kN} \quad \checkmark \quad \text{OK}$$

Design Bearing Capacity of WGN-B1120 (250 x 125 BRS) bearer for short term loading:

$$\Phi R_u = \lambda \cdot C \Phi R_{0x}$$

$$\lambda = 0.8$$

Time effect factor

$$C = 0.64$$

Adjustment factor for end use

From Wagners CFT Design Guide table B-7 the reference bearing capacity

$$\Phi R_{0s} = 19.91 \text{ kN (note that this is the same as for WGN-S3000 (125SHS))}$$

$$\Phi R_u = \lambda \cdot C \Phi R_{0s} = 0.8 \times 0.64 \times 19.91 = 10.19 \text{ kN} < 26.27 \text{ kN} \quad \text{NOT OK}$$

Provide inserts at bearer to column positions.

Design Axial Compressive Capacity of WGN-B1120 (250 x 125 BRS) bearer short term loading:

$$\Phi N_{uc} = \lambda C \Phi N_0$$

$$\lambda = 0.8$$

Time effect factor

$$L_{\text{eff,Cx}} = 594 \text{ mm}$$

Effective Length for compression x axis buckling

$$L_{\text{eff,Cy}} = 1925 \text{ mm}$$

Effective Length for compression y axis buckling

$$C = 0.64$$

Adjustment factor for end use

From Wagners CFT Design Guide table B.1 the reference section compression capacity $\Phi N_{0c} = 614.76 \text{ kN}$

From Wagners CFT Design Guide table B.7 the reference member compression capacity $\Phi N_{0cx} = 614.76 \text{ kN}$

From Wagners CFT Design Guide table B.9 the reference member compression capacity $\Phi N_{0cy} = 614.76 \text{ kN}$

$$\Phi N_{uc} = 0.8 \times 0.64 \times 614.76 = 314.75 \text{ kN} > N_c^* \quad \checkmark \quad \text{OK}$$

3.1.2.2 BEARERS - COMBINED ACTIONS LONG TERM:

As the bearers form part of the lateral bracing system of the walkway (i.e. columns/piles, bearers and diagonal braces) they attract axial forces from the lateral load analysis.

Bending and Compression

$$N_c^*/\Phi N_c + M_x^*/\Phi M_{bx} + M_y^*/\Phi M_{by} \leq 1.0$$

$$0.1 / 157.4 + 1.12 / 18.29 = 0.062 \leq 1.0 \quad \sqrt{\quad} \quad \text{OK}$$

Bending and Shear

$$(M_x^* / \Phi M_{bx})^2 + (V^* / \Phi V_u)^2 \leq 1.0$$

$$(1.12 / 18.29)^2 + (2.4 / 39.45)^2 = 0.007 \leq 1.0 \quad \sqrt{\quad} \quad \text{OK}$$

3.1.2.3 BEARERS - COMBINED ACTIONS SHORT TERM:

As the bearers form part of the lateral bracing system of the walkway (i.e. columns/piles, bearers and diagonal braces) they attract axial forces from the lateral load analysis.

Combined Bending and and Compression

$$N_c^*/\Phi N_c + M_x^*/\Phi M_{bx} + M_y^*/\Phi M_{by} \leq 1.0$$

$$4.6 / 314.75 + 12.64 / 36.59 = 0.288 \leq 1.0 \quad \sqrt{\quad} \quad \text{OK}$$

Combined Bending and Shear

$$(M_x^* / \Phi M_{bx})^2 + (V^* / \Phi V_u)^2 \leq 1.0$$

$$(12.64 / 36.59)^2 + (26.27/78.90)^2 = 0.230 \leq 1.0 \quad \sqrt{\quad} \quad \text{OK}$$

3.1.2.4 BEARERS - SERVICEABILITY LIMIT STATE DESIGN:

Conservatively consider bearers as simple span (ignoring end cantilevers)

Maximum deflection of single span bearer:

$$\Delta_{\text{single span}} = (K_{\text{cr}}(t)/C) \times k_1 \times (wL^4/EI) + k_2(wL^2/GA_{\text{web}})$$

where $K_{\text{cr}}(t)$ is the duration dependent deflection multiplier for creep

C is the end use factor

$$k_1 = .013$$

$$k_2 = .125$$

For short term loading G+ΨQ

$$K_{\text{cr}}(t)/C = 1.014/.75 = 1.35$$

$$\text{LC 3} \rightarrow w = 11.86 \text{ kN/m}$$

$$\begin{aligned} \Delta_{\text{single span}} &= 1.35 \times (.013 \times 11.86 \times 1925^4 / (36300 \times 36.9 \times 10^6)) + .125 \times 11.86 \times 1925^2 / (4280 \times 2688) \\ &= 2.77 \text{ mm} = \text{Span}/695. \quad \quad \quad \checkmark \quad \text{OK} \end{aligned}$$

For long term loading G only

$$K_{\text{cr}}(t)/C = 1.44/.75 = 1.92$$

$$w = 1.34 \times 5.594 + 0.117$$

$$= 7.61 \text{ kN/m}$$

$$\begin{aligned} \Delta_{\text{single span}} &= 1.92 \times (.013 \times 7.61 \times 1925^4 / (35400 \times 36.9 \times 10^6)) + .125 \times 7.61 \times 1925^2 / (4287 \times 2688) \\ &= 2.53 \text{ mm} = \text{Span}/760. \quad \quad \quad \checkmark \quad \text{OK} \end{aligned}$$

$$\text{Deflection Overhang} = 225 / 0.570 \text{ (calculated from single span with cantilever / overhangs)}$$

$$= \text{Span} / 385 < \text{Span} / 125 \quad \quad \quad \checkmark \quad \text{OK}$$

3.1.2.5 NATURAL FREQUENCY:

$$f_n = 0.18 \times (g/\Delta)^{0.5}$$
$$w_{(\text{joists})} = 5.94 \text{ kg/m} = 5.75 \text{ m} \times 0.058 \text{ kN/m} \times 5 / 1.925 \text{ m} = 0.86 \text{ kN/m}$$
$$w_{(\text{decking})} = 29.74 \text{ kg/m}^2 = 0.3 \text{ kPa} \times 5.75 \text{ kN/m} = 1.73 \text{ kN/m}$$
$$w_{(\text{bearer})} = 11.88 \text{ kg/m} = 0.116 \text{ kN/m}$$
$$w_{(\text{Total})} = 0.86 + 1.73 + 0.116 = 2.71 \text{ kN/m}$$
$$E = 3.63\text{e}7 \text{ kPa}$$
$$I_x_{(\text{WGN-B1120 (250x125 BRS)})} = 3.751\text{e-}5 \text{ m}^4$$
$$L = 1.925\text{m}$$

Based on **single span** deflection criteria:

$$\Delta_{\text{single span}} = (5/384) \times (wL^4/EI)$$
$$f_n = 0.18 \times (9.81 / (5/384 \times (2.71 \times 1.925^4) / (3.63\text{e}7 \times 3.751\text{e-}5)))^{0.5}$$
$$f_n = 29.9 \text{ Hz} > 5\text{Hz} \quad \checkmark \quad \text{OK}$$

Allowance for live load contribution can be added at design engineers discretion. Refer to AISC DG11 for recommendations on live loads applications for frequency analysis.

3.1.3 TOTAL SYSTEM ANALYSIS:

$$\text{Joist Deflection} = 11.46 \text{ mm}$$
$$\text{Bearer Deflection} = 2.77 \text{ mm}$$
$$\text{Total Deflection} = 14.23 \text{ mm}$$
$$\text{Deflection Ratio} = 4475 \text{ mm} / 14.23 \text{ mm}$$
$$= \text{Span} / 314 < \text{Span} / 250 \quad \checkmark \quad \text{OK}$$

3.1.3.1 NATURAL FREQUENCY:

$$f_n = 0.18 \times (g / \Delta_j + \Delta_g)^{0.5}$$
$$f_n = 0.18 \times (9.81 / ((11.46/1000) + (2.77/1000)))^{0.5}$$
$$f_n = 4.72 \text{ Hz} < 5\text{Hz} \quad \text{NOT OK}$$

Therefore the designer should check further dynamic assessment of total.

3.1.3.2 VIBRATION CRITERIA:

For lightweight structures it is essential to assess vibration performance of the system to ensure pedestrians are comfortable at all times. Large deflections and bounce in a structure are cause for concern with the general public. It is for this reason that vibration is primarily a serviceability limit state design.

This design example will address checking vibration of a single beam to AS/NZS 1170.0 Table C1 with a 1kN static live load midspan and ensuring deflections are less than 1-2mm.

This is one method of verifying the dynamic performance of the floor system. Further analysis may be required and is at the discretion of the design engineer to assess how lively a flooring system may be.

Check joist point load deflection:

$$\Delta_{\text{single span}} = (1/48) \times (P \times L^3 / EI)$$

$$\Delta_{\text{two span}} = (0.015) \times (P \times L^3 / EI)$$

$$\Delta_{\text{single span}} = (1/48) \times 1000 \times 4475^3 / (3.63 \times 10^7 \times 6.89 \times 10^6) \times 1000 = 7.46 \text{ mm} > 2 \text{ mm} \quad \text{NOT OKAY}$$

$$\Delta_{\text{two span}} = (0.015) \times 1000 \times 4475^3 / (3.63 \times 10^7 \times 6.89 \times 10^6) \times 1000 = 5.31 \text{ mm} > 2 \text{ mm} \quad \text{NOT OKAY}$$

Therefore the designer should check further dynamic assessment of floor system. The above is conservative assuming the joist does not load share between other joists.

3.1.4 DIAGONAL BRACE:

Member type = WGN-S1000 (100SHS)

Max Length = 2660 mm

Column effective lengths $L_x = L_y = 2660 \text{ mm}$

3.1.4.1 DIAGONAL BRACE - ULTIMATE LIMIT STATE DESIGN:

The loads in the brace resulting from lateral loading are considered in this example to be short term loads and therefore the long term load case is not considered.

$$N_c^* = 8.22 \text{ kN}$$

$$N_t^* = 8.22 \text{ kN}$$

Design short term axial Compressive Capacity of WGN-S1000 (100SHS):

$$\Phi N = \lambda \cdot C \cdot \Phi N_0$$

$$\lambda = 0.8$$

Time effect factor

$$C = 0.64$$

Adjustment factor for end use

From Wagners CFT Design Guide table B-1 the reference section compression capacity $\Phi N_{0c} = 201.42 \text{ kN}$

From Wagners CFT Design Guide table B-3 the reference member compression capacity $\Phi N_{0cx} \Phi N_{0cy} = 107.35 \text{ kN}$
 $\Phi N_{uc} = 0.8 \times 0.64 \times 107.35 = 54.96 \text{ kN} > 8.22 \text{ kN} \quad \checkmark \quad \text{OK}$

The Serviceability Limit State not applicable to diagonal brace.

3.1.5 HANDRAIL POSTS:

Member type = WGN-S3000 (125SHS)
 Height = 1425 mm

ASCE-PRE
 STANDARD (2010)
 CL 6.2

3.1.5.1 HANDRAIL POSTS - ULTIMATE LIMIT STATE DESIGN:

The lateral and vertical loading on the handrail posts is considered to be short term loading. The resulting member forces are :

$M_x^* = 1.6 \text{ kNm}$, 0.9 from handrail lateral load.

$M_y^* = 3.5 \text{ kNm}$

$N_c^* = 1.1 \text{ kN}$ From handrail vertical UDL load

$N_t^* = 0.0 \text{ kN}$ No axial load tension capacity check required.

$V_x^* = 3.8 + 0.64 = 4.44 \text{ kN}$

$V_z^* = 1.25 \text{ kN}$

Design Moment Capacity of WGN-S3000 (125SHS) handrail post for short term loading:

$$\Phi M_b = \lambda.C\Phi M_{ob}$$

$$\text{where } \Phi M_{ob} = \min(\Phi M_{s}, \Phi M_b)$$

$\lambda = 0.8$ Time effect factor

$C = 0.64$ Adjustment factor for end use

From Wagners CFT Design Guide table B-1 the reference section moment capacity $\Phi M_{os} = 33.85 \text{ kNm}$

From Wagners CFT Design Guide table B-2 the reference member moment capacity $\Phi M_{ob} = 33.85 \text{ kNm}$

$\Phi M_{bx} = \Phi M_{by} = \lambda.C\Phi M_{ob} = 1.0 \times 0.64 \times 33.85 = 17.33 \text{ kNm} > 3.5 \quad \checkmark \quad \text{OK but need to check combined actions.}$

See next page.

Design Shear Capacity of WGN-S3000 (125SHS) for short term loading:

$$\Phi V_u = \lambda \cdot C \Phi V_{0x}$$

$\lambda = 0.8$ Time effect factor
 $C = 0.64$ Adjustment factor for end use

From Wagners CFT Design Guide table B-1 the reference shear capacity

$$\Phi V_{0s} = 77.05 \text{ kN}$$

$$\Phi V_u = \lambda \cdot C \Phi V_{0s} = 0.8 \times 0.64 \times 77.05 = 39.44 \text{ kN} > 4.44 \text{ kN} \quad \checkmark \quad \text{OK}$$

Design Axial Compressive Capacity of 125 SHS handrail post short term loading:

$$\Phi N_{uc} = \lambda C \Phi N_{0}$$

$\lambda = 0.8$ Time effect factor
 $L_{e,Cx} = 2400 \text{ mm}$ Effective Length for compression buckling
Considering as unrestrained cantilever
 $C = 0.64$ Adjustment factor for end use

From Wagners CFT Design Guide table B-1 the reference section compression capacity $\Phi N_{0c} = 307 \text{ kN}$

From Wagners CFT Design Guide table B-3 the reference member compression capacity $\Phi N_{0cx} = 253.64 \text{ kN}$

$$\Phi N_{uc} = 0.8 \times 0.64 \times 253.64 = 129.84 \text{ kN} > N_c^* \quad \checkmark \quad \text{OK}$$

Handrail Post - Combined Actions:

$$N_c^* / \Phi N_c + M_x^* / \Phi M_{bx} + M_y^* / \Phi M_{by} \leq 1.0$$

$$1.1 / 129.84 + 1.6 / 17.33 = 0.1 \leq 1.0 \quad \checkmark \quad \text{OK}$$

Combined Bending and Shear

$$(M_x^* / \Phi M_{bx})^2 + (V^* / \Phi V_u)^2 \leq 1.0$$

$$(1.6 / 17.33)^2 + (4.44 / 39.44)^2 = 0.02 \leq 1.0 \quad \checkmark \quad \text{OK}$$

Wagners CFT
Design Guide:
CI 4.2

Wagners CFT
Design Guide:
CI 4.3

ULS checks of Handrail and mid-rail

For the ULS design of the steel handrail refer to appropriate steel design manual.

The mid-rail is a simple bending member. As there are examples of the design of bending members else where in this example the mid-rail is not provided in this example.

3.1.5.2 SERVICEABILITY LIMIT STATE DESIGN:

Combination Case = Handrail loading

Deflection of Posts = 6.0 mm from wind-blowing

Deflection Ratio = 1425 mm / 6.0 mm

= Height / 237 < Height / 60

√ OK

3.1.6 HANDRAIL SYSTEM ANALYSIS

AS 2156.2 has provisions for determining the type of barrier required on the structure under consideration.

Effective Fall Height, h_{eff} :

$$h_{eff} = h_f + h_i$$

h_f = maximum fall height = 2.6m max.

h_i = impact surface value = 0 (favourable)

$$h_{eff} = 2.6 + 0 = 2.6\text{m}$$

Track Class = 3

Allowable Barrier Type = C

Please refer to AS 2156.2 Cl 3.4 (c) for a description of this barrier type. This example presumes that the handrails and posts comply with this clause.

3.1.6.1 HANDRAIL POST SLS CHECK:

Post type = WGN-S3000 (125 SHS)

Height = 1.2 m

Span = 2.0 m max.

Top rail load = 0.36 kN/m

Deflection of cantilever = $\Delta = PL^3/3EI$

E = 36300 MPa

$$I_{xx} = 6.98e6 \text{ mm}^4$$
$$L = (\text{Post height}) + (\text{Replas thickness}) + (125\text{mm}/2 \text{ joist}) + (125\text{mm}/2 \text{ joist}) + (100\text{mm}/2 \text{ tie-brace})$$
$$L = (1200 \text{ mm}) + (50 \text{ mm}) + (62.5 \text{ mm}) + (62.5 \text{ mm}) + (50 \text{ mm}) = 1425 \text{ mm}$$

$$\Delta = 0.36 \times 2.0\text{m} \times 1425^3 / (3 \times 36300 \times 6.98e6)$$
$$\Delta = 2.8\text{mm}$$

$$\text{Deflection Ratio} = 1425\text{mm} / 2.8\text{mm}$$
$$= \text{Height} / 508 < \text{Height} / 60 \quad \checkmark \quad \text{OK}$$

3.1.7 COLUMNS:

Member type = WGN-S3000 (125SHS)
Height = 2200 mm

3.1.7.1 COLUMNS - ULTIMATE LIMIT STATE DESIGN:

$$M_x^* = 1.19 \text{ kNm}$$
$$N_C^* = 44.7 \text{ kN}$$
$$N_T^* = 8.58 \text{ kN}$$
$$V_y^* = 12.8 + 1.26 = 14.06 \text{ kN}$$

Design Moment Capacity of WGN-S3000 (125SHS) Column long term:

$$\Phi M_b = \lambda.C\Phi M_{ob}$$

where $\Phi M_{ob} = \min(f_{Ms}, f_{Mb})$

$$\lambda = 0.4 \quad \text{Time effect factor}$$
$$C = 0.64 \quad \text{Adjustment factor for end use}$$

From Wagners CFT Design Guide table B-1 the reference section moment capacity $\Phi M_{os} = 33.85 \text{ kNm}$

From Wagners CFT Design Guide table B-2 the reference member moment capacities = $\Phi M_{ob} = 33.85 \text{ kNm}$

$$\Phi M_b = \lambda.C\Phi M_{ob} = 0.4 \times 0.64 \times 33.85 = 8.67 \text{ kNm} > 1.19 \quad \checkmark \quad \text{OK}$$

Design Shear Capacity of WGN-S3000 (125 SHS) Column for long term loading:

$$\Phi V_u = \lambda.C\Phi V_{ox}$$

$\lambda = 0.4$ Time effect factor
 $C = 0.64$ Adjustment factor for end use

From Wagners CFT Design Guide table B-1 the reference shear capacity

$$\Phi V_{0s} = 77.1 \text{ kN}$$

$$\Phi V_u = \lambda \cdot C \cdot \Phi V_{0s} = 0.4 \times 0.75 \times 77.1 = 19.74 \text{ kN} > 14.06 \text{ kN} \quad \checkmark \quad \text{OK}$$

Design Axial Compressive Capacity of WGN-S3000 (125 SHS) Column long term loading:

$\Phi N_{uc} = \lambda C \Phi N_0$
 $\lambda = 0.4$ Time effect factor
 $C = 0.64$ Adjustment factor for end use
 $L_e = 2200 \text{ mm}$ Effective Length for compression

From Wagners CFT Design Guide table B-1 the reference section compression capacity $\Phi N_{0c} = 307 \text{ kN}$

From Wagners CFT Design Guide table B-3 the reference member compression capacity $\Phi N_{0cx} = 253 \text{ kN}$

$$\Phi N_{uc} = 0.4 \times 0.64 \times 253 = 64.7 \text{ kN} > N_c^* \quad \checkmark \quad \text{OK}$$

Design Axial Tensile Capacity of WGN-S3000 (125 SHS) Column long term loading:

$\Phi N_{ut} = \lambda C \Phi N_0$
 $\lambda = 0.4$ Time effect factor
 $C = 0.64$ Adjustment factor for end use

From Wagners CFT Design Guide table B-1 the reference section tension capacity $\Phi N_{0t} = 576 \text{ kN}$

$$\Phi N_{ut} = 0.4 \times 0.64 \times 576 = 147.46 \text{ kN} > N_c^* \quad \checkmark \quad \text{OK}$$

Design Moment Capacity of WGN-S3000 (125 SHS) Column short term:

$\Phi M_b = \lambda \cdot C \cdot \Phi M_{0b}$
where $\Phi M_{0b} = \min(fM_s, fM_b)$
 $\lambda = 0.8$ Time effect factor
 $C = 0.64$ Adjustment factor for end use

From Wagners CFT Design Guide table B-1 the reference section moment

capacity $\Phi M_{os} = 33.85$ kNm

From Wagners CFT Design Guide table B-2 the reference member moment capacities = $\Phi M_{ob} = 33.85$ kNm

$$\Phi M_b = \lambda.C\Phi M_{ob} = 0.8 \times 0.64 \times 33.85 = 17.33 \text{ kNm} > 1.19 \quad \checkmark \quad \text{OK}$$

Shear Design Capacity of WGN-S3000 (125SHS) Column for short term loading:

$$\Phi V_u = \lambda.C\Phi V_{ox}$$

$\lambda = 0.8$ Time effect factor
 $C = 0.75$ Adjustment factor for end use

From Wagners CFT Design Guide table B-1 the reference shear capacity $\Phi V_{os} = 77.1$ kN

$$\Phi V_u = \lambda.C\Phi V_{os} = 1.0 \times 0.64 \times 77.1 = 39.47 \text{ kN} > 14.06 \text{ kN} \quad \checkmark \quad \text{OK}$$

Design Axial Compressive Capacity of WGN-S3000 (125SHS) Column short term loading:

$$\Phi N_{uc} = \lambda C \Phi N_{o}$$

$\lambda = 0.8$ Time effect factor
 $C = 0.64$ Adjustment factor for end use
 $L_e = 2200$ mm Effective Length for compression

From Wagners CFT Design Guide table B-1 the reference section compression capacity $\Phi N_{oc} = 307.43$ kN

From Wagners CFT Design Guide table B-3 the reference member compression capacity $\Phi N_{ocx} = 253$ kN

$$\Phi N_{uc} = 0.8 \times 0.64 \times 253 = 129.54 \text{ kN} > N_c^* \quad \checkmark \quad \text{OK}$$

Design Axial Tensile Capacity of WGN-S3000 (125SHS) Column short term loading:

$$\Phi N_{ut} = \lambda C \Phi N_o$$

$\lambda = 0.8$ Time effect factor
 $C = 0.64$ Adjustment factor for end use

From Wagners CFT Design Guide table B-1 the reference section compression capacity $\Phi N_{ot} = 585 \text{ kN}$

$$\Phi N_{ut} = 0.8 \times 0.64 \times 576.7 = 295.2 \text{ kN} > N_t^* \quad \checkmark \quad \text{OK}$$

3.1.7.2 COLUMNS - COMBINED ACTIONS LONG TERM:

Combined Bending and Compression long term

$$N_c^*/\Phi N_c + M_x^*/\Phi M_{bx} + M_y^*/\Phi M_{by} \leq 1.0$$

$$44.7 / 64.7 + 1.19 / 8.67 = 0.83 \leq 1.0 \quad \checkmark \quad \text{OK}$$

Combined Bending and Tension long term

$$N_t^*/\Phi N_t + M_x^*/\Phi M_{bx} + M_y^*/\Phi M_{by} \leq 1.0$$

$$8.58 / 368.6 + 1.19 / 8.67 = 0.16 \leq 1.0 \quad \checkmark \quad \text{OK}$$

Combined Bending and Shear long term

$$(M_x^* / \Phi M_{bx})^2 + (V^* / \Phi V_u)^2 \leq 1.0$$

$$(1.19 / 8.67)^2 + (14.06 / 19.74)^2 = 0.526 \leq 1.0 \quad \checkmark \quad \text{OK}$$

3.1.7.3 COLUMNS - COMBINED ACTIONS SHORT TERM:

Combined Bending and and Compression short term

$$N_c^*/\Phi N_c + M_x^*/\Phi M_{bx} + M_y^*/\Phi M_{by} \leq 1.0$$

$$44.7 / 129.54 + 1.19 / 17.33 = 0.413 \leq 1.0 \quad \checkmark \quad \text{OK}$$

Combined Bending and Tension short term

$$N_c^*/\Phi N_t + M_x^*/\Phi M_{bx} + M_y^*/\Phi M_{by} \leq 1.0$$

$$8.58 / 295.2 + 1.19 / 17.33 = 0.097 \leq 1.0 \quad \checkmark \quad \text{OK}$$

Combined Bending and Shear short term

$$(M_x^* / \Phi M_{bx})^2 + (V^* / \Phi V_u)^2 \leq 1.0$$

$$(1.19 / 17.33)^2 + (14.06 / 39.47)^2 = 0.13 \leq 1.0 \quad \checkmark \quad \text{OK}$$

3.1.7.4 COLUMNS - SERVICEABILITY LIMIT STATE DESIGN:

Deflection of Columns is negligible due to diagonal brace taking sway actions out of the frame. Vertical loads are not high enough to encounter deflections due to axial compression.

3.1.8 DECKING:

The decking design is carried out using Wagners CFT span tables which are based on experimental tests. Refer to appendix D for span tables.

3.1.9 NATURAL FREQUENCY:

A dynamic analysis was undertaken using the 3D model in Microstran. The results of this test would nominate the first mode, or natural frequency of the entire structure. We can use this to compare to the manual calculations detail previously.

$f_n = 12 \text{ Hz} > 5 \text{ Hz}$	From Microstran
$f_n = 7.89 \text{ Hz} > 5 \text{ Hz}$	From Manual Calculations

Therefore the manual calculations provide a fairly conservative estimation of the natural frequency of this structure.

4. CONNECTION DESIGN

All connection forces are quoted in Design ultimate forces.

4.1.1 JOISTS TO BEARERS:

Connection Type: 3/ 6-6 S.S. Rivets

Wagners CFT Design Guide table C.2.3 gives $\Phi V_r = 7.73 \text{ kN}$

For short term load case $\lambda C = 0.64$

Therefore $\Phi V_r = 0.64 \times 7.73 = 4.95 \text{ kN}$

$V_z^* = 2.02 + 2.83 = 4.85 \text{ kN} / 3 \text{ rivets per side} / 2 \text{ sides}$

$V_z^* = 0.81 \text{ kN per rivet}$

$\Phi V = 4.95 \text{ kN}$ $V_z^* < \Phi V$ \checkmark OK

$N_T^* = 7.22 / 3 / 2 = 1.2 \text{ kN per rivet}$

$\Phi N_T = 4.94 \text{ kN}$ $N_T^* < \Phi N_T$ \checkmark OK

4.1.2 BEARERS TO PILES:

Member Type: WGN-B1120 (250x125 BRS) to WGN-S3000 (125SHS)

Connection Type: 2/M20 G316 S.S. bolts with inserts.

$$V_z^* = 26.72 \text{ kN} / 2 \text{ bolts}$$

$$V_z^* = 13.4 \text{ kN per bolt} \quad \text{bolts in single shear}$$

Wagners CFT Design Guide table C-1 gives $\Phi V_{b0} = 37.6 \text{ kN}$ with insert to work in transverse direction.

For short term load case $\lambda C = 0.8 \times 0.64$

$$\text{Therefore } \Phi V_b = 0.8 \times 0.64 \times 37.6 = 19.25 \text{ kN} \quad V_z^* < \Phi V_b \quad \checkmark \quad \text{OK}$$

4.1.3 DIAGONAL BRACE TO PILES:

Member Type: WGN-S1000 (100SHS) to WGN-S3000 (SHS)

Connection Type: 1/M20 G316 S.S. bolt with inserts.

$$V_z^* = 8.22 \text{ kN} \quad \text{bolts in single shear}$$

Wagners CFT Design Guide table C-1 gives $\Phi V_{b0} = 36.1 \text{ kN}$ with insert to work in transverse direction.

For short term load case $\lambda C = 0.8 \times 0.64$

$$\text{Therefore } \Phi V_b = 0.8 \times 0.64 \times 36.1 = 18.48 \text{ kN} \quad V_z^* < \Phi V_b \quad \checkmark \quad \text{OK}$$

4.1.4 HANDRAIL POSTS TO BEARERS:

Member Type: WGN-S1000 (100SHS) to WGN-S3000 (SHS)

Connection Type: 2/M16 G316 S.S. bolt with glued inserts.

$$M_x^* = 1.61 \text{ kNm}$$

$$d = 0.125 + 0.125 = 0.25 \text{ m}$$

$$F^* = M / d$$

$$F^* = 1.61 / 0.25 = 6.44 \text{ kN} \quad \text{couple force}$$

Bolt to joist will be in tension, bolt to bearer will be in shear.

$$V_y^* = 6.44 \text{ kN}$$

Wagners CFT Design Guide table C-1 gives $\Phi V_{b0} = 28.1 \text{ kN}$ with insert to work in transverse direction.

For short term load case $\lambda C = 0.8 \times 0.64$

$$\text{Therefore } \Phi V_b = 0.8 \times 0.64 \times 28.1 = 14.39 \text{ kN} \quad V_y^* < \Phi V_b \quad \checkmark \quad \text{OK}$$

The design engineer should also check bending of angle brackets at handrail post to joist/bearer locations to ensure adequate plate capacity. This is to be undertaken using normal engineering analysis.

5. FOUNDATION DESIGN

The type of foundation used depends largely on the underlying strata and its performance data. It is for this reason that Wagners CFT strongly recommends that a qualified geotechnical engineer will undertake a thorough site investigation to analyse soil types, bearing capacities, ground water, site classification and recommended foundation systems.

Wagners CFT structures can be supported on various types of foundation systems, for example:

- » Wagners CFT Driven Piles
- » Reinforced Concrete Bored Piers
- » Reinforced Concrete - Pad or Strip Footings
- » Screw piles
- » Short Driven Reinforced Concrete Piers

The application of a foundation system relies on the design engineers understanding of the founding material, access to the site and the client's budget. The design of any of these foundation systems is no different to a normal engineering application. In the case of driven piles, the design engineer should be aware of the effects of positive and negative skin friction in underlying soil strata and the effect that this may have on the end design.

For this example we assess the performance of Driven Piles.

5.1 PILE DESIGN

5.1.1 PILE LOADING

To start the analysis we need to know the maximum compression and uplift forces imposed on each pile.

$$N_c^* = 44.7 \text{ kN} \quad \text{From Microstran}$$

$$N_T^* = 8.58 \text{ kN} \quad \text{From Microstran}$$

5.1.2 DESIGN GEOTECHNICAL STRENGTH OF DRIVEN PILES

In this example we choose to use the provisions of AS2870 Appendix G. Section G4.1 explains that this method is valid where the driving hammer mass is greater than the pile mass as is usually the case in domestic construction and with Wagners CFT piles.

$$R_{ug} = (R_{ug})_2 - (R_{ug})_1 \quad \text{eq G4.3(1)}$$

Where:

R_{ug} = ultimate geotechnical strength of pile, kN

$(R_{ug})_1$ = ultimate geotechnical strength of pile determined at $0.75H_s$

$(R_{ug})_2$ = ultimate geotechnical strength of pile determined at final depth

$$(R_{ug})_1 \text{ and } (R_{ug})_2 = 0.4 \cdot (W_h \times h_h) / S \quad \text{eq G4.3(2)}$$

Where:

W_h = hammer weight = 500 kg / 101.9 = 4.91 kN

h_h = drop height of hammer = 0.75 m

Try S = pile set, average for five blows = 0.012 m

$$(R_{ug})_2 = 0.4 \times (4.91 \times 0.75) / 0.012 = 122.8 \text{ kN}$$

For $(R_{ug})_1$ assume S at $H_s = 1.0\text{m}$

$(R_{ug})_1 = 0.4 \times (4.91 \times 0.75) / 1.0 = 1.47 \text{ kN}$ to be confirmed by test pile or by geotech.

$$R_{ug} = 122.8 - 1.47 = 121.3 \text{ kN}$$

The design ultimate pile strength = $\Phi_g R_{ug}$

$\Phi_g = 0.45$ for compression loads and 0.35 for tension loads

$$\Phi_g R_{ug,C} = 0.45 \times 121.23 = 54.6 \text{ kN} > N_C^* \quad \checkmark \quad \text{OK}$$

$$\Phi_g R_{ug,T} = 0.35 \times 121.23 = 42.43 \text{ kN} > N_T^* \quad \checkmark \quad \text{OK}$$

The worst "average blows" from the example geotechnical report is approximately 15mm. To check the ultimate geotechnical capacity of the pile, we can calculate the geotechnical capacity due to end bearing and shaft adhesion. Both of these factors have also been provided in the report.

Ultimate Shaft Adhesion, $q_s = 30 \text{ kPa}$

Ultimate End Bearing, $q_b = 1500 \text{ kPa}$

The following method is used to estimate the length of pile embedment required into the earth.

5.1.3 END BEARING RESISTANCE

$$P_b = A_b \cdot Q_b$$

$$P_b = d^2 \times q_s = 0.125^2 \times 1500$$

$$P_b = 23.44 \text{ KN}$$

5.1.4 SHAFT RESISTANCE

$$P_s = A_s \cdot q_s \quad \text{Ignore the first 1.0m of material}$$
$$P_s = 4 \times d \times L = 4 \times 0.125 \times L \times 30$$
$$P_s = 15L \text{ kN}$$

5.1.5 TOTAL PILE COMPRESSION RESISTANCE

$$P_t = P_s + P_b = 44.7 \text{ kN} \quad P_t = N^*_c$$
$$44.7 = 0.45 \times 15L + 0.45 \times 23.44$$
$$44.7 = 06.75L + 10.548$$
$$L = (44.7 - 10.548) / 6.75 = 5.05 \text{ m} + 1.0 \text{ m (ignored length)}$$
$$L = 6.05 \text{ m} \quad \text{minimum pile length to resist } N^*_c$$

Check:

$$P_t = 15 \times 6.05 \times 0.45 + 23.44 \times 0.45 = 51.38 \text{ kN} > N^*_c \quad \checkmark \quad \text{OK}$$
$$\Phi_g R_{ug,C} = 44.16 \text{ kN} < P_t \quad \checkmark \quad \text{OK}$$

5.1.6 TOTAL PILE TENSION RESISTANCE

$$P_s = 15L \quad P_s = N^*_T$$
$$8.58 = 15L$$
$$L = (8.58/15)/0.35$$
$$L = 1.65 \text{ m} + 1.0 \text{ m} = 2.65 \text{ m} \quad \text{minimum pile length to resist } N^*_T$$

Check:

$$P_s = 15 \times 41.65 \times 0.35 = 8.66 \text{ kN} > N^*_T \quad \checkmark \quad \text{OK}$$
$$\Phi_g R_{ug,T} = 34.35 \text{ kN} < P_s \quad \checkmark \quad \text{OK}$$

Therefore we can expect a piling rig to drop a 500kg hammer, 750mm and with a set of 15mm per blow, averaged over 5 blows to achieve the required geotechnical capacity to withstand the design forces on this structure. Correlating the average blows from the driven pile formulas with the strata conditions found in the geotechnical condition aids in predicting pile pull up / embedment length. Further to this we can estimate that the pile embedment will be in the order of 6m before final set is reached based upon standard skin friction and end bearing calculation. Some sites may require pre-boring or pile tests to confirm adequate geotechnical strength is reached. It should also be noted that 5% of driven piles should be load tested to confirm adequate structural capacity for Quality Assurance purposes.

6. WAGNERS CFT WORKING DRAWINGS AND CERTIFICATION PROCESS

The final process will require detailed checking of documented drawings by Wagners CFT. After the design engineer is satisfied with the level of documentation and accuracy in the design, they may certify the drawings for construction.

APPENDICES

Appendix A: Sectional and Mechanical Properties of Wagners CFT Structural Sections

A.1 Standard Structural Sections

- Table A.1.1 Circular Hollow Sections (CHS)
- Table A.1.2 Square Hollow Sections (SHS)
- Table A.1.3 Rectangular Hollow Sections (RHS)
- Table A.1.4 Flat Sections (FS)

A.2 Bonded Structural Sections

- Table A.2.1 Bonded Rectangular Sections (BRS)
- Table A.2.2 Bonded Square Sections (BSS)
- Table A.2.3 Bonded I Sections (BIS)
- Table A.2.4 Bonded U Sections (BUS)

Appendix B: Section and Member Capacities

- Table B-1 Reference Section Capacities*
- Table B-1a Reference Section Capacities*
- Table B-2 Reference Moment Capacities for Members Without Full Lateral Restraint *
- Table B-2a Reference Moment Capacities for Members Without Full Lateral Restraint *
- Table B-3 Reference Capacities for Members Subject to Axial Compression*
- Table B-3a Reference Capacities for Members Subject to Axial Compression*
- Table B-4 Serviceability Load Limit for Members Subject to Axial Compression
- Table B-4a Serviceability Load Limit for Members Subject to Axial Compression
- Table B-5 Reference Capacities for Members Subject to Axial Compression*
- Table B-5a Reference Capacities for Members Subject to Axial Compression*
- Table B-6 Serviceability Load Limit for Members Subject to Axial Compression
- Table B-6a Serviceability Load Limit for Members Subject to Axial Compression
- Table B-7 Reference Capacities* for Crushing / Bearing Capacity of SHS Sections
- Table B-8 Reference Capacities* for Crushing / Bearing Capacity of SHS Sections with Grout

Appendix C: Connection Capacities

C.1 Bolted Connection Capacity

- Table C-1.1 Reference Capacities* for Bolted Connections
- Table C-1.2 Reference Capacities* for Bolted Connections
- Table C-1.3 Reference Capacities* for Bolted Connections
- Table C-1.4 Reference Capacities* for Bolted Pull-Out Capacity

C.2 Riveted Connection Capacity

- Table C.2.1 Reference Capacities* for Riveted-Bracket Connections
- Table C.2.2 Reference Capacities* for Riveted-Bracket Connections

- Table C.2.3 Reference Capacities* for Riveted-Bracket Connections

- Table C.2.4 Reference Capacities* for Rivet Pullout Capacities

C.3 Decking to Joist

- Table C.3 Reference Capacities* for Screwed Joist-Decking Connections

Appendix D: FRP Composite Decking

Appendix E: Wagners CFT CHS Piling Technical Data

Appendix F: Accessories

- F.1 Anti-Crush Inserts
- F.2 Endcaps
- F.3 Standard Brackets

APPENDIX A: PHYSICAL, MECHANICAL AND SECTIONAL PROPERTIES OF WAGNERS CFT STRUCTURAL SECTIONS

A.1 STANDARD STRUCTURAL SECTIONS

A.1.1 CIRCULAR HOLLOW SECTIONS (CHS)

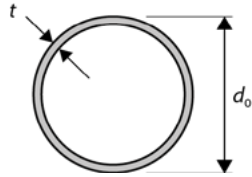

DIMENSIONS AND SECTION PROPERTIES

CIRCULAR HOLLOW SECTIONS

Fibre Reinforced Polymer (FRP)

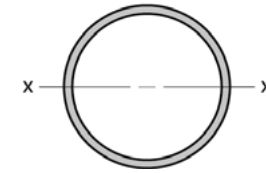

PRODUCT CODE	MEMBER DESIGNATION	DIMENSIONS				SECTION PROPERTIES					
		Designation		Mass per meter	External Surface Area per m	Cross Section Area A_g	About any axis			Torsion Constant J	Torsion Modulus C
		Outer Diameter d_o	Thick. t				I	Z	r		
mm	mm	kg/m	m ² /m	mm ²	10 ⁶ mm ⁴	10 ³ mm ³	mm	10 ⁶ mm ⁴	10 ³ mm ³		
WGN-C1000	89CHS	88.9	6.0	3.17	0.279	1563	1.35	30.4	29.4	2.70	60.7
WGN-C7000	152CHS	151.9	7.9	7.36	0.477	3574	9.29	122.3	51.0	18.58	244.7
WGN-C6000	178CHS	177.9	9.85	10.71	0.559	5200	18.42	207.1	59.5	36.84	414.2
WGN-C3000	230CHS	230.1	9.7	13.86	0.723	6716	40.86	355.2	78.0	81.72	710.3
WGN-C4000	293CHS	293.0	9.5	17.43	0.920	8461	85.10	580.9	100.3	170.20	1161.8
WGN-C5000	301CHS	301.0	13.5	25.13	0.946	12193	126.26	838.9	101.8	252.52	1677.9
WGN-C8000	356CHS	356.0	13.5	29.92	1.118	14526	213.33	1198.5	121.2	426.66	2397.0

MECHANICAL PROPERTIES

PROPERTY	RESULT								UOM	STANDARD
	C1000	C1010	C7000	C6000	C3000	C4000	C5000	C8000		
Tensile Strength – Longitudinal	361	307	635	635	635	635	635	635	MPa	ISO 527-4
Tensile Modulus of Elasticity – Longitudinal	35720	22920	35405	35405	35405	35405	35405	35405		
Compressive Strength – Longitudinal	267	295	395	395	395	395	395	395	MPa	ASTM D6641
Compressive Modulus of Elasticity – Longitudinal	39200	29220	41178	41178	41178	41178	41178	41178		
In-Plane Shear Strength – Longitudinal	91	92	93	93	93	93	93	93	MPa	ASTM D7078

*The values in the table are the characteristic values to be used for design in normal ambient conditions. It does not include adjustment factors to account for temperature, humidity, and chemical environments.

PHYSICAL PROPERTIES

PROPERTY	NOTATION	VALUE	UNIT	TEST METHOD
Density	r	2.030	kg/m ³	ASTM D792
Barcol Hardness		60	-	ASTM D2583
Water Absorption		0.2	%	ISO 62
Glass Transition Temperature	T_g	130	°C	ASTM D7028
Fibre Mass Fraction	W_f	77.4	%	ISO 1172
Fibre Volume Fraction	V_f	57.7	%	
Coefficient of Thermal Expansion – Longitudinal	α_L	5.03x10 ⁻⁶	/°C	ISO 11359-2

The values in the table are mean values obtained from tests at ambient temperature and relative humidity.

A.1.2 SQUARE HOLLOW SECTIONS (SHS)

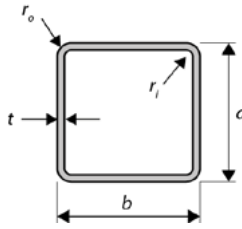

DIMENSIONS AND SECTION PROPERTIES

SQUARE HOLLOW SECTIONS

Fibre Reinforced Polymer (FRP)

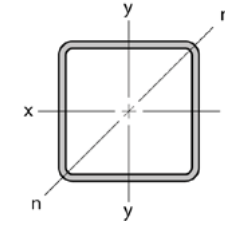

PRODUCT CODE	MEMBER DESIGNATION	DIMENSIONS							SECTION PROPERTIES							
		Designation			Outside Corner Radius	Inside Corner Radius	Mass	External Surface Area	Cross Section Area	About x- and y-axis			About n-axis		Torsion Constant	Torsion Modulus
		Depth	Width	Thick.						I_x	Z_x	r_x	I_n	Z_n		
		d	b	t	r_o	r_i	per m	per m	A_g	10^6mm^4	10^3mm^3	mm	10^6mm^4	10^3mm^3	10^6mm^4	10^3mm^3
mm	mm	mm	mm	mm	kg/m	m^2/m	mm^2									
WGN-S1000	100SHS	100	100	5.2	10.0	4.75	3.85	0.383	1905	2.80	56.1	38.4	2.81	42.3	4.6	84.3
WGN-S2000	104SHS	104	104	7	10.0	4.75	5.38	0.399	2650	4.11	79.0	39.4	4.12	59.3	6.6	115.7
WGN-S3000	125SHS	125	125	6.4	10.0	4.75	6.07	0.483	2970	6.89	110.2	48.2	6.90	81.9	10.9	162.9

MECHANICAL PROPERTIES

PROPERTY	RESULT			UOM	STANDARD
	WGN-S1000	WGN-S2000	WGN-S3000		
Tensile Strength – Longitudinal	610	595	610	MPa	ISO 527-4
Tensile Modulus of Elasticity – Longitudinal	36300	37680	36300	MPa	
Poisson's Ratio – Longitudinal	0.28	0.28	0.28	-	
Tensile Strength – Transverse	55	55	55	MPa	ISO 527-4
Tensile Modulus of Elasticity – Transverse	10800	10800	10800	MPa	
Poisson's Ratio – Transverse	0.09	0.09	0.09	-	
Compressive Strength – Longitudinal	485	405	485	MPa	ASTM D6641
Compressive Modulus of Elasticity – Longitudinal	33300	38240	33300	MPa	
Compressive Strength – Transverse	120	120	120	MPa	ASTM D6641
Compressive Modulus of Elasticity – Transverse	11600	11600	11600	MPa	
In-Plane Shear Strength – Longitudinal	84	71	84	MPa	ASTM D7078
In-Plane Shear Modulus of Elasticity – Longitudinal	4280	6040	4280	MPa	
Interlaminar Shear Strength	44	43	44	MPa	ASTM D2344
Izod Pendulum Impact Resistance - Longitudinal**	3204	3204	3204	J/m	ASTM D256
Izod Pendulum Impact Resistance - Transverse	554	554	554	J/m	

PHYSICAL PROPERTIES

PROPERTY	NOTATION	VALUE	UNIT	TEST METHOD
Density	r	2,030	kg/m^3	ASTM D792
Barcol Hardness		60	-	ASTM D2583
Water Absorption		0.2	%	ISO 62
Glass Transition Temperature	T_g	130	$^{\circ}\text{C}$	ASTM D7028
Fibre Mass Fraction	W_f	77.4	%	ISO 1172
Fibre Volume Fraction	V_f	57.7	%	
Coefficient of Thermal Expansion – Longitudinal	α_L	5.03×10^{-6}	$/^{\circ}\text{C}$	ISO 11359-2

The values in the table are mean values obtained from tests at ambient temperature and relative humidity.

*The values in the table are the characteristic values to be used for design in normal ambient conditions. It does not include adjustment factors to account for temperature, humidity, and chemical environments.

**The test samples exceeded the test equipment capacity with 21.7J hammer, hence the true value is expected to be higher than the reported value.

A.1.3 RECTANGULAR HOLLOW SECTIONS (RHS)

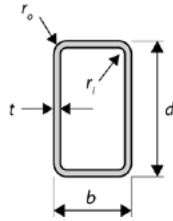

DIMENSIONS AND SECTION PROPERTIES

RECTANGULAR HOLLOW SECTIONS

Fibre Reinforced Polymer (FRP)

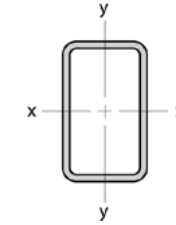

PRODUCT CODE	MEMBER DESIGNATION	DIMENSIONS							SECTION PROPERTIES								
		Designation			Outside Corner Radius	Inside Corner Radius	Mass	External Surface Area	Cross Section Area	About x-axis			About y-axis			Torsion Constant	Torsion Modulus
		Depth	Width	Thick.						I_x	Z_x	r_x	I_y	Z_y	r_y		
d	b	t	r_o	r_i	per m	per m	A_g	10^6mm^4	10^3mm^3	mm	10^6mm^4	10^3mm^3	mm	10^6mm^4	10^3mm^3		
WGN-R1000	100x75RHS	100	75	5.2	10.0	4.75	3.86	0.333	1645	2.22	44.4	36.7	1.41	37.7	29.3	2.9	61.0
WGN-R4000	150x100RHS	152.4	101.4	11.1	5.0	8.0	10.43	0.499	5187	15.47	203.0	54.6	7.88	155.5	39.0	15.8	239.2
WGN-R5000	250x100RHS	250	100	8.1	5.0	8.0	11.72	0.691	5441	41.36	330.9	87.2	9.40	188.1	41.6	24.2	322.7

MECHANICAL PROPERTIES

PROPERTY	RESULT			UOM	STANDARD
	WGN-R1000	WGN-R4000	WGN-R5000		
Tensile Strength – Longitudinal	570	610	610	MPa	ISO 527-4
Tensile Modulus of Elasticity – Longitudinal	37600	36300	36300	MPa	
Poisson's Ratio – Longitudinal	0.3	0.28	0.28	-	
Tensile Strength – Transverse	35	55	55	MPa	ISO 527-4
Tensile Modulus of Elasticity – Transverse	9190	10800	10800	MPa	
Poisson's Ratio – Transverse	0.07	0.09	0.09	-	
Compressive Strength – Longitudinal	425	485	485	MPa	ASTM D6641
Compressive Modulus of Elasticity – Longitudinal	34000	33300	33300	MPa	
Compressive Strength – Transverse	108	120	120	MPa	ASTM D6641
Compressive Modulus of Elasticity – Transverse	11000	11600	11600	MPa	
In-Plane Shear Strength – Longitudinal	51	84	84	MPa	ASTM D7078
In-Plane Shear Modulus of Elasticity – Longitudinal	4690	4280	4280	MPa	
Interlaminar Shear Strength	42	44	44	MPa	ASTM D2344
Izod Pendulum Impact Resistance - Longitudinal**	3204	3204	3204	J/m	ASTM D256
Izod Pendulum Impact Resistance - Transverse	554	554	554	J/m	

PHYSICAL PROPERTIES

PROPERTY	NOTATION	VALUE	UNIT	TEST METHOD
Density	r	2,030	kg/m ³	ASTM D792
Barcol Hardness		60	-	ASTM D2583
Water Absorption		0.2	%	ISO 62
Glass Transition Temperature	T_g	130	°C	ASTM D7028
Fibre Mass Fraction	W_f	77.4	%	ISO 1172
Fibre Volume Fraction	V_f	57.7	%	
Coefficient of Thermal Expansion – Longitudinal	α_L	5.03×10^{-6}	/°C	ISO 11359-2

The values in the table are mean values obtained from tests at ambient temperature and relative humidity.

*The values in the table are the characteristic values to be used for design in normal ambient conditions. It does not include adjustment factors to account for temperature, humidity, and chemical environments.

**The test samples exceeded the test equipment capacity with 21.7J hammer, hence the true value is expected to be higher than the reported value.

A.1.4 FLAT SECTIONS (FS)

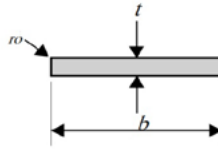

DIMENSIONS AND SECTION PROPERTIES

FLAT SECTIONS

Fibre Reinforced Polymer (FRP)

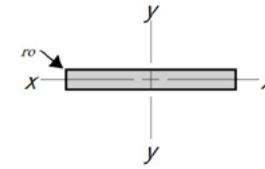

PRODUCT CODE	MEMBER DESIGNATION	DIMENSIONS					SECTION PROPERTIES							
		Designation		Corner Radius	Mass	External Surface Area	Cross Section Area	About x- axis			About y-axis			Torsion Constant
		Width	Thick.					I_x	Z_x	r_x	I_y	Z_y	r_y	
		b	t	r_o	per m	per m	A_g							10^6mm^4
mm	mm	mm	kg/m	m^2/m	mm^2									
WGN-F1000	6mm flat	1200	6.4	-	15.6	2.413	7680	0.026	8.2	1.85	921.6	1536.0	346.41	0.10
WGN-F3000	24mm flat	300	24.0	10	14.6	0.641	7176	0.343	28.6	6.91	53.5	356.5	86.32	1.38

MECHANICAL PROPERTIES

PROPERTY	RESULT		UOM	STANDARD
	WGN-F1000	WGN-F3000		
Tensile Strength – Longitudinal	374	520	MPa	ISO 527-4
Tensile Modulus of Elasticity – Longitudinal	26112	39134	MPa	
Poisson's Ratio – Longitudinal	0.32	0.33	-	
Tensile Strength – Transverse	26	12	MPa	
Tensile Modulus of Elasticity – Transverse	2242	10605	MPa	
Poisson's Ratio – Transverse	0.14	0.28	-	
Compressive Strength – Longitudinal	266	307	MPa	ISO 14126
Compressive Modulus of Elasticity – Longitudinal	25400	36575	MPa	
Compressive Strength – Transverse	71	79	MPa	
Compressive Modulus of Elasticity – Transverse	5498	10534	MPa	
In-Plane Shear Strength – Longitudinal	62	34	MPa	ASTM D5379M
In-Plane Shear Modulus of Elasticity – Longitudinal	9564	5256	MPa	
In-Plane Shear Strength – Transverse	71	18	MPa	
In-Plane Shear Modulus of Elasticity – Transverse	832	3993	MPa	

The values in the table are the characteristic values calculated using kt method of AS1170.0, to be used for design in normal ambient conditions. It does not include adjustment factors to account for temperature, humidity, and chemical environments.

PHYSICAL PROPERTIES

PROPERTY	NOTATION	VALUE	UNIT	TEST METHOD
Density	r	1,979	kg/m ³	ASTM D792
Barcol Hardness		60	-	ASTM D2583
Fibre Mass Fraction	W_f	75	%	ISO 1172
Fibre Volume Fraction	V_f	54	%	

The values in the table are mean values obtained from tests at ambient temperature and relative humidity.

A.2 BONDED STRUCTURAL SECTIONS

ADHESIVE PROPERTIES

The adhesive used for bonded beams is a proprietary thixotropic, solvent free, toughened epoxy resin. The adhesive has been specially formulated for composites and provides excellent peel strength of the bond.

PROPERTY	NOTATION	VALUE	UNIT	TEST METHOD
Tensile Strength	f_t	34.1	MPa	ISO 527-2
Tensile Modulus	E_t	2409	MPa	ISO 527-2
Lap Shear Strength	f_v	11.9	MPa	ASTM D3163
Heat Deflection Temperature	HDT	85	°C	ISO 75

1. The properties in the table are as per the ATL Engineering Data sheet dated 23/9/09.
2. The values in the table are based on a cure schedule of 24 hours @ ambient + 8 hours @ 80 °C.
3. The values in the table are the design values to be used in normal ambient conditions. It does not include adjustment factor to account for temperature, humidity, and chemical environments.



A.2.1: BONDED RECTANGULAR SECTIONS (BRS)

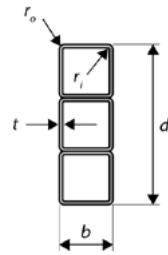

DIMENSIONS AND SECTION PROPERTIES

BONDED RECTANGULAR SECTIONS

Fibre Reinforced Polymer (FRP)

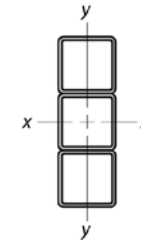

PRODUCT CODE	MEMBER DESIGNATION	DIMENSIONS							SECTION PROPERTIES							
		Designation			Outside Corner Radius	Inside Corner Radius	Mass	External Surface Area	Cross Section Area	About x-axis			About y-axis			Torsion Constant
		Depth	Width	Thick.						I_x	Z_x	r_x	I_y	Z_y	r_y	
		d	b	t	r_o	r_i	per m	per m	A_g	10^6mm^4	10^3mm^3	mm	10^6mm^4	10^3mm^3	mm	10^6mm^4
WGN-B1020	200x100x5.2BRS	200	100	5.2	10.0	4.75	7.70	0.61	3811	15.1	151.3	63.0	5.6	112.1	38.4	9.1
WGN-B1030	300x100x5.2BRS	300	100	5.2	10.0	4.75	11.55	0.83	5716	46.5	310.1	90.2	8.4	168.2	38.4	13.7
WGN-B1040	400x100x5.2BRS	400	100	5.2	10.0	4.75	15.40	1.05	7621	106.5	532.4	118.2	11.2	224.3	38.4	18.2
WGN-B1050	500x100x5.2BRS	500	100	5.2	10.0	4.75	19.25	1.27	9527	204.6	818.2	146.5	14.0	280.3	38.4	22.8
WGN-B1060	300x200x5.2BRS	300	200	5.2	10.0	4.75	23.10	0.96	11432	93.0	620.2	90.2	45.4	454.0	63.0	27.3
WGN-B1120	250x125x6.4BRS	250	125	6.4	10.0	4.75	12.14	0.76	5939	37.0	295.8	78.9	13.8	220.3	48.2	21.9
WGN-B1130	375x125x6.4BRS	375	125	6.4	10.0	4.75	18.21	1.03	8909	113.5	605.1	112.8	20.7	330.5	48.2	32.8
WGN-B1140	500x125x6.4BRS	500	125	6.4	10.0	4.75	24.28	1.30	11879	259.5	1038.2	147.8	27.5	440.6	48.2	43.7
WGN-B1150	625x125x6.4BRS	625	125	6.4	10.0	4.75	30.35	1.57	14848	498.4	1595.0	183.2	34.4	550.8	48.2	54.7
WGN-B1160	375x250x6.4BRS	375	250	6.4	10.0	4.75	36.42	1.21	17818	226.9	1210.2	112.8	110.9	887.3	78.9	65.6

A.2.2: BONDED SQUARE SECTIONS (BSS)

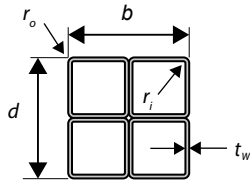

DIMENSIONS AND SECTION PROPERTIES

BONDED SQUARE SECTIONS

Fibre Reinforced Polymer (FRP)

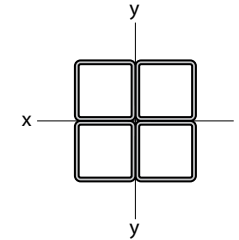

PRODUCT CODE	MEMBER DESIGNATION	DIMENSIONS						SECTION PROPERTIES							
		Designation			Outside Corner Radius	Inside Corner Radius	Mass	External Surface Area	Cross Section Area	About x-axis and y-axis			About n-axis		Torsion Constant
		Depth	Width	Thick.						$I_{x,y}$	$Z_{x,y}$	$r_{x,y}$	I_n	Z_n	
		d	b	t	r_o	r_i	per m	per m	A_g	10^6mm^4	10^3mm^3	mm	10^6mm^4	10^3mm^3	10^6mm^4
mm	mm	mm	mm	mm	kg/m	m ² /m	mm ²								
WGN-B2020	200x200x5.2BSS	200	200	5.2	10.0	4.75	15.40	0.766	7621	30.3	302.7	63.0	30.2	220.4	18.2
WGN-B2120	250x250x6.4BSS	250	250	6.4	10.0	4.75	24.28	0.966	11879	73.9	591.5	78.9	73.2	425.7	43.7

A.2.3: BONDED I SECTIONS (BIS)

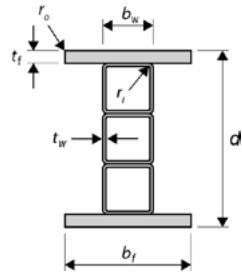

DIMENSIONS AND SECTION PROPERTIES

BONDED I-SECTIONS

Fibre Reinforced Polymer (FRP)

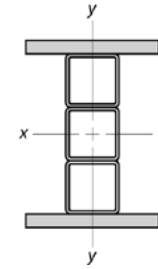

PRODUCT CODE	MEMBER DESIGNATION	DIMENSIONS										SECTION PROPERTIES						
		Depth d	Designation			Outside Corner Radius r _o	Inside Corner Radius r _i	Mass per m	External Surface Area per m	Cross Section Area A _g	About x-axis			About y-axis			Torsion Constant J	
			Width b _f	b _w	Thick. t _f						t _w	I _x	Z _x	r _x	I _y	Z _y		r _y
WGN-B3020	248x300x5.2BIS	248	300	100	24.0	5.2	10.0	4.75	36.83	1.47	18163	195.9	1579.4	103.8	112.6	750.4	78.7	10.5
WGN-B3030	348x300x5.2BIS	348	300	100	24.0	5.2	10.0	4.75	40.68	1.66	20068	423.9	2436.0	145.3	115.4	769.0	75.8	15.0
WGN-B3040	448x300x5.2BIS	448	300	100	24.0	5.2	10.0	4.75	44.53	1.85	21973	752.2	3358.0	185.0	118.2	787.7	73.3	19.6
WGN-B3050	548x300x5.2BIS	548	300	100	24.0	5.2	10.0	4.75	48.38	2.04	23879	1190.4	4344.6	223.3	121.0	806.4	71.2	24.1
WGN-B3120	298x300x6.4BIS	298	300	125	24.0	6.4	10.0	4.75	41.27	1.52	20291	307.0	2060.6	123.0	120.7	804.8	77.1	23.3
WGN-B3130	423x300x6.4BIS	423	300	125	24.0	6.4	10.0	4.75	47.34	1.76	23261	685.4	3240.4	171.6	127.6	850.7	74.1	34.2
WGN-B3140	548x300x6.4BIS	548	300	125	24.0	6.4	10.0	4.75	53.41	2.00	26231	1245.4	4545.3	217.9	134.5	896.6	71.6	45.1
WGN-B3150	673x300x6.4BIS	673	300	125	24.0	6.4	10.0	4.75	59.48	2.24	29200	2010.4	5974.4	262.4	141.4	942.5	69.6	56.1

A.2.4: BONDED U SECTIONS (BUS)

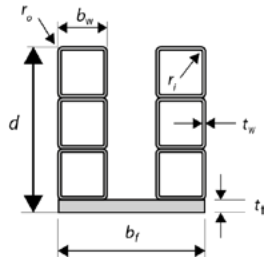

DIMENSIONS AND SECTION PROPERTIES

BONDED U-SECTIONS

Fibre Reinforced Polymer (FRP)

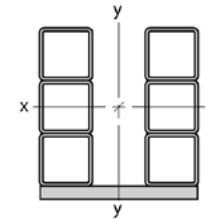

PRODUCT CODE	MEMBER DESIGNATION	DIMENSIONS									SECTION PROPERTIES									
		Designation					Outside Corner Radius	Inside Corner Radius	Mass per m	External Surface Area per m	Cross Section Area A_g	About x-axis				About y-axis				Torsion Constant J
		Depth d	Width b_f b_w		Thick. t_f t_w							r_o	r_i	I_x	$Z_{x,max}$	$Z_{x,min}$	r_x	I_y	$Z_{y,max}$	
mm	mm	mm	mm	mm	mm	mm	kg/m	m ² /m	mm ²	10 ⁶ mm ⁴	10 ³ mm ³	10 ³ mm ³	mm	10 ⁶ mm ⁴	10 ³ mm ³	10 ³ mm ³	mm	10 ⁶ mm ⁴		
WGN-B4020	224x300x5.2BUS	224	300	100	24.0	5.2	10.0	4.75	30.0	1.45	14797	76.9	1104.0	498.7	72.1	140.9	940.8	937.9	97.6	19.6
WGN-B4030	324x300x5.2BUS	324	300	100	24.0	5.2	10.0	4.75	37.7	1.90	18608	209.0	1874.1	983.9	106.0	184.6	1232.2	1229.3	99.6	28.7
WGN-B4040	424x300x5.2BUS	424	300	100	24.0	5.2	10.0	4.75	45.4	2.34	22419	432.5	2769.9	1614.8	138.9	228.2	1522.9	1519.9	100.9	37.8
WGN-B4050	524x300x5.2BUS	524	300	100	24.0	5.2	10.0	4.75	53.1	2.79	26230	767.2	3791.8	2385.0	171.0	271.9	1814.5	1811.4	101.8	46.9
WGN-B4120	274x600x6.4BUS	274	600	125	24.0	6.4	10.0	4.75	53.4	2.25	26231	196.8	2781.6	968.6	86.6	1125.2	3756.9	3744.3	207.1	46.5
WGN-B4130	399x600x6.4BUS	399	600	125	24.0	6.4	10.0	4.75	65.6	2.79	32170	544.1	4540.8	1949.0	130.1	1474.0	4920.0	4906.5	214.1	68.4
WGN-B4140	524x600x6.4BUS	524	600	125	24.0	6.4	10.0	4.75	77.7	3.34	38109	1134.0	6552.0	3231.5	172.5	1822.8	6082.9	6068.8	218.7	90.3
WGN-B4150	649x600x6.4BUS	649	600	125	24.0	6.4	10.0	4.75	89.8	3.88	44049	2016.4	8812.1	4798.9	214.0	2171.5	7245.8	7231.2	222.0	112.1

* BUS girders are designed from first principles engineering. These tables are for information only as critical engineering checks are to be carried out by the design engineer prior to ordering and installing these sections. Please contact Wagners CFT for more information.

APPENDIX B: SECTION AND MEMBER CAPACITIES

TABLE B-1
REFERENCE SECTION CAPACITIES*
CHS, RHS, SHS AND BRS SECTIONS
about x- and y-axis

PRODUCT CODE	MEMBER DESIGNATION	AXIAL TENSION**	AXIAL COMPRESSION	MOMENT		SHEAR	
		ΦN_{ot} kN	ΦN_{oc} kN	x-axis ΦM_{osx} kNm	y-axis ΦM_{osy} kNm	x-axis ΦV_{ox} kN	y-axis ΦV_{oy} kN
WGN-C1000	89CHS	149.3	292.1	17.4 [^]	17.4 [^]	46.2	46.2
WGN-C7000	152CHS	652.5	988.2	48.0 [^]	48.0 [^]	108.0	108.0
WGN-C6000	178CHS	964.1	1437.9	92.0 [^]	92.0 [^]	157.2	157.2
WGN-C3000	230CHS	1272.0	1857.1	142.4 [^]	142.4 [^]	203.0	203.0
WGN-C4000	293CHS	1626.7	2339.5	159.8 [^]	159.8 [^]	255.7	255.7
WGN-C5000	301CHS	2345.9	3371.4	318.1 [^]	318.1 [^]	368.5	368.5
WGN-C8000	356CHS	2817.7	4016.4	329.6	329.6	439.0	439.0
WGN-R1000	100x75RHS	266.7	152.6	15.0 [^]	7.8 [^]	29.9	21.2
WGN-R4000	150x100RHS	951.1	1030.5	63.6	48.8	171.1	110.0
WGN-R5000	250x100RHS	1022.5	219.9	104.3	30.4 [^]	198.0	79.6
WGN-S1000	100SHS	347.9	201.4	17.7 [^]	17.7 [^]	48.6	48.6
WGN-S3000	125SHS	576.7	307.4	33.9 [^]	33.9 [^]	77.1	77.1
WGN-B1020	200x100x5.2BRS	718.2	402.9	30.7 [^]	25.6	97.3	97.3
WGN-B1030	300x100x5.2BRS	1088.3	604.4	66.8 [^]	38.3	145.9	145.9
WGN-B1040	400x100x5.2BRS	1458.4	805.8	74.7	51.1	194.5	194.5
WGN-B1050	500x100x5.2BRS	1828.7	1007.3	114.7	63.8	243.2	243.2
WGN-B1120	250x125x6.4BRS	1181.9	614.8	71.5 [^]	58.0 [^]	154.1	154.1
WGN-B1130	375x125x6.4BRS	1787.3	922.2	124.3 [^]	88.3 [^]	231.2	231.2
WGN-B1140	500x125x6.4BRS	2392.7	1229.6	169.6 [^]	120.7 [^]	308.2	308.2
WGN-B1150	625x125x6.4BRS	2997.9	1536.9	260.6	145.1	385.3	385.3

* In the context of this manual Reference capacities include Φ factor but not λ and C factors.

** 1 x 22mm diameter through hole in section. The capacities are the net section capacity not the connection capacity.

[^]Characteristic Experimental moment capacity obtained from full-scale four-point bend test as per ASTM D6109.

TABLE B-1A
 REFERENCE SECTION CAPACITIES*
BIS SECTIONS
 about x- and y-axis

PRODUCT CODE	MEMBER DESIGNATION	AXIAL TENSION**	AXIAL COMPRESSION	MOMENT		SHEAR	
		ΦN_{ot} kN	ΦN_{oc} kN	x-axis ΦM_{osx} kNm	y-axis ΦM_{osy} kNm	x-axis ΦV_{ox} kN	y-axis ΦV_{oy} kN
WGN-B3020	248x300x5.2BIS	2736.4	1994.0	267.9	129.2	97.3	97.3
WGN-B3030	348x300x5.2BIS	3025.2	2195.6	388	131.7	145.9	145.9
WGN-B3040	448x300x5.2BIS	3314.0	2397.1	513	134.3	194.5	194.5
WGN-B3050	548x300x5.2BIS	3603.0	2598.7	645.3	136.8	243.2	243.2
WGN-B3120	298x300x6.4BIS	3055.0	2214.0	326.2	136.6	154.1	154.1
WGN-B3130	423x300x6.4BIS	3505.3	2524.5	461.4	142.9	231.2	231.2
WGN-B3140	548x300x6.4BIS	3955.6	2835.0	649.6	149.1	308.2	308.2
WGN-B3150	673x300x6.4BIS	4405.7	3145.2	831.9	155.4	385.3	385.3

* In the context of this manual Reference capacities include Φ factor but not λ and C factors.

** 1 x 22mm diameter through hole in section. The capacities are the net section capacity not the connection capacity.

Designs with BIG sections will usually be governed by serviceability criteria over ultimate bending strength. If the designer finds themselves with BIG sections with large bending moments (i.e. > 40% of ULS bending capacity with λ and C factors set to 1.0) they are advised to contact Wagners CFT to confirm BIG capacities with additional testing.

TABLE B-2
REFERENCE MOMENT CAPACITIES FOR MEMBERS
WITHOUT FULL LATERAL RESTRAINT *
SHS, RHS AND BRS SECTIONS
about x- axis

PRODUCT CODE	MEMBER DESIGNATION	REFERENCE MOMENT CAPACITIES ΦM_{obx} kNm FOR MEMBERS WITHOUT FULL LATERAL RESTRAINT												
		Effective Length L_e metres												
		1.0	1.5	2.0	2.5	3.0	3.5	4.0	4.5	5.0	6.0	7.0	8.0	9.0
WGN-R1000	100x75RHS	15.0 [^]	15.0 [^]	15.0 [^]	15.0 [^]	15.0 [^]	14.9	13.0	11.6	10.4	8.7	7.5	6.5	5.8
WGN-R4000	150x100RHS	63.6	63.6	63.6	63.6	63.6	63.6	63.6	63.0	56.7	47.2	40.5	35.4	31.5
WGN-R5000	250x100RHS	104.3	104.3	104.3	104.3	104.3	104.3	104.3	94.7	85.2	71.0	60.9	53.3	47.4
WGN-S1000	100SHS	17.7 [^]	17.7 [^]	17.7 [^]	17.7 [^]	17.7 [^]	17.7 [^]	17.7 [^]	17.7 [^]	17.7 [^]	15.0	12.9	11.3	10.0
WGN-S3000	125SHS	33.9 [^]	33.9 [^]	33.9 [^]	33.9 [^]	33.9 [^]	33.9 [^]	33.9 [^]	33.9 [^]	33.9 [^]	33.9 [^]	31.3	27.4	24.4
WGN-B1020	200x100x5.2BRS	30.7 [^]	30.7 [^]	30.7 [^]	30.7 [^]	30.7 [^]	30.7 [^]	30.7 [^]	30.7 [^]	30.7 [^]	30.7 [^]	30.7 [^]	28.3	25.2
WGN-B1030	300x100x5.2BRS	66.8 [^]	66.8 [^]	66.8 [^]	66.8 [^]	66.8 [^]	66.8 [^]	66.8 [^]	66.8 [^]	66.8 [^]	66.8 [^]	66.8 [^]	49.5	44.0
WGN-B1040	400x100x5.2BRS	74.7	74.7	74.7	74.7	74.7	74.7	74.7	74.7	74.7	74.7	74.7	74.1	65.9
WGN-B1050	500x100x5.2BRS	114.7	114.7	114.7	114.7	114.7	114.7	114.7	114.7	114.7	114.7	114.7	101.7	90.4
WGN-B1120	250x125x6.4BRS	71.5 [^]	71.5 [^]	71.5 [^]	71.5 [^]	71.5 [^]	71.5 [^]	71.5 [^]	71.5 [^]	71.5 [^]	71.5 [^]	71.5 [^]	68.8	61.1
WGN-B1130	375x125x6.4BRS	124.3 [^]	124.3 [^]	124.3 [^]	124.3 [^]	124.3 [^]	124.3 [^]	124.3 [^]	124.3 [^]	124.3 [^]	124.3 [^]	124.3 [^]	120.3	106.9
WGN-B1140	500x125x6.4BRS	169.6 [^]	169.6 [^]	169.6 [^]	169.6 [^]	169.6 [^]	169.6 [^]	169.6 [^]	169.6 [^]	169.6 [^]	169.6 [^]	169.6 [^]	169.6 [^]	159.9
WGN-B1150	625x125x6.4BRS	260.6	260.6	260.6	260.6	260.6	260.6	260.6	260.6	260.6	260.6	260.6	247.1	219.7

* In the context of this manual Reference capacities include Φ factor but not λ and C factors.
[^]Characteristic Experimental Capacity.

Linear interpolation is permissible within the bounds of the tabulation. The accuracy will be approximately within +/- 0.5% Do not extrapolate.

TABLE B-2A
REFERENCE MOMENT CAPACITIES FOR MEMBERS
WITHOUT FULL LATERAL RESTRAINT *
BIS SECTIONS
about x- axis

PRODUCT CODE	MEMBER DESIGNATION	REFERENCE MOMENT CAPACITIES ΦM_{obx} kNm FOR MEMBERS WITHOUT FULL LATERAL RESTRAINT												
		Effective Length L_b metres												
		1	1.5	2	2.5	3	3.5	4	4.5	5	6	7	8	9
WGN-B3020	248x300x5.2BIS	267.9	267.9	267.9	267.9	267.9	267.9	267.9	267.9	267.9	267.9	267.9	267.9	267.9
WGN-B3030	348x300x5.2BIS	388.0	388	388.0	388.0	388.0	388.0	388.0	388.0	388.0	388.0	388.0	388.0	388.0
WGN-B3040	448x300x5.2BIS	513.0	513	513.0	513.0	513.0	513.0	513.0	513.0	513.0	513.0	513.0	513.0	513.0
WGN-B3050	548x300x5.2BIS	645.3	645.3	645.3	645.3	645.3	645.3	645.3	645.3	645.3	645.3	645.3	645.3	645.3
WGN-B3120	298x300x6.4BIS	326.2	326.2	326.2	326.2	326.2	326.2	326.2	326.2	326.2	326.2	326.2	326.2	326.2
WGN-B3130	423x300x6.4BIS	461.4	461.4	461.4	461.4	461.4	461.4	461.4	461.4	461.4	461.4	461.4	461.4	461.4
WGN-B3140	548x300x6.4BIS	649.6	649.6	649.6	649.6	649.6	649.6	649.6	649.6	649.6	649.6	649.6	649.6	649.6
WGN-B3150	673x300x6.4BIS	831.9	831.9	831.9	831.9	831.9	831.9	831.9	831.9	831.9	831.9	831.9	831.9	831.9

* In the context of this manual Reference capacities include Φ factor but not λ and C factors.

Linear interpolation is permissible within the bounds of the tabulation. The accuracy will be approximately within +/- 0.5% Do not extrapolate.

Designs with BIS sections will usually be governed by serviceability criteria over ultimate bending strength. If the designer finds themselves with BIS sections with large bending moments (i.e. > 40% of ULS bending capacity with λ and C factors set to 1.0) they are advised to contact Wagners CFT to confirm BIS capacities with additional testing.

TABLE B-3
 REFERENCE CAPACITIES FOR MEMBERS
 SUBJECT TO AXIAL COMPRESSION *
CHS, RHS, SHS AND BRS SECTIONS
 buckling about x- axis

PRODUCT CODE	MEMBER DESIGNATION	REFERENCE MEMBER AXIAL COMPRESSION CAPACITIES ΦN_{cox} kN FOR MEMBERS WITHOUT FULL LATERAL RESTRAINT											
		Effective Length L_b metres											
		1.0	1.5	2.0	2.5	3.0	3.5	4.0	4.5	5.0	6.0	7.0	8.0
WGN-C1000	89CHS	292.1	162.4	91.4	58.5	40.6	29.8	22.8	18.0	14.6	10.2	7.5	5.7
WGN-C7000	152CHS	988.2	988.2	660.8	422.9	293.7	215.8	165.2	130.5	105.7	73.4	53.9	41.3
WGN-C6000	178CHS	1437.9	1437.9	1310.1	838.5	582.3	427.8	327.5	258.8	209.6	145.6	106.9	81.9
WGN-C3000	230CHS	1857.1	1857.1	1857.1	1857.1	1291.6	948.9	726.5	574.0	465.0	322.9	237.2	181.6
WGN-C4000	293CHS	2339.5	2339.5	2339.5	2339.5	2339.5	1976.3	1513.1	1195.6	968.4	672.5	494.1	378.3
WGN-C5000	301CHS	3371.4	3371.4	3371.4	3371.4	3371.4	2932.2	2245.0	1773.8	1436.8	997.8	733.0	561.2
WGN-C8000	356CHS	4016.4	4016.4	4016.4	4016.4	4016.4	4016.4	3793.1	2997.0	2427.6	1685.8	1238.6	948.3
WGN-R1000	100x75RHS	152.6	152.6	125.9	80.6	55.9	41.1	31.5	24.9	20.1	14.0	10.3	7.9
WGN-R4000	150x100RHS	1030.5	1030.5	883.5	565.4	392.6	288.5	220.9	174.5	141.4	98.2	72.1	55.2
WGN-R5000	250x100RHS	219.9	219.9	219.9	219.9	219.9	219.9	219.9	219.9	219.9	219.9	194.2	148.7
WGN-S1000	100SHS	201.4	201.4	167.7	107.4	74.6	54.8	41.9	33.1	26.8	18.6	13.7	10.5
WGN-S3000	125SHS	307.4	307.4	307.4	253.6	176.1	129.4	99.1	78.3	63.4	44.0	32.4	24.8
WGN-B1020	200x100x5.2BRS	402.9	402.9	402.9	402.9	402.0	295.4	226.1	178.7	144.7	100.5	73.8	56.5
WGN-B1030	300x100x5.2BRS	604.4	604.4	604.4	604.4	604.4	604.4	604.4	550.2	445.7	309.5	227.4	174.1
WGN-B1040	400x100x5.2BRS	805.8	805.8	805.8	805.8	805.8	805.8	805.8	805.8	805.8	708.9	520.8	398.8
WGN-B1050	500x100x5.2BRS	1007.3	1007.3	1007.3	1007.3	1007.3	1007.3	1007.3	1007.3	1007.3	1007.3	1000.5	766.0
WGN-B1120	250x125x6.4BRS	614.8	614.8	614.8	614.8	614.8	614.8	532.1	420.4	340.5	236.5	173.7	133.0
WGN-B1130	375x125x6.4BRS	922.2	922.2	922.2	922.2	922.2	922.2	922.2	922.2	922.2	725.4	532.9	408.0
WGN-B1140	500x125x6.4BRS	1229.6	1229.6	1229.6	1229.6	1229.6	1229.6	1229.6	1229.6	1229.6	1229.6	1218.5	932.9
WGN-B1150	625x125x6.4BRS	1536.9	1536.9	1536.9	1536.9	1536.9	1536.9	1536.9	1536.9	1536.9	1536.9	1536.9	1536.9

* In the context of this manual Reference capacities include Φ factor but not λ and C factors.

Linear interpolation is permissible within the bounds of the tabulation. The accuracy will be approximately within +/- 0.5% Do not extrapolate.

TABLE B-3A
REFERENCE CAPACITIES FOR MEMBERS
SUBJECT TO AXIAL COMPRESSION *
BIS SECTIONS
buckling about x- axis

PRODUCT CODE	MEMBER DESIGNATION	REFERENCE MEMBER AXIAL COMPRESSION CAPACITIES ΦN_{cox} kN FOR MEMBERS WITHOUT FULL LATERAL RESTRAINT											
		Effective Length L_{ec} metres											
		1	1.5	2	2.5	3	3.5	4	4.5	5	6	7	8
WGN-B3020	248x300x5.2BIS	1994.0	1994.0	1994.0	1994.0	1994.0	1994.0	1994.0	1994.0	1994.0	1459.1	1072.0	820.8
WGN-B3030	348x300x5.2BIS	2195.6	2195.6	2195.6	2195.6	2195.6	2195.6	2195.6	2195.6	2195.6	2195.6	2195.6	1758.1
WGN-B3040	448x300x5.2BIS	2397.1	2397.1	2397.1	2397.1	2397.1	2397.1	2397.1	2397.1	2397.1	2397.1	2397.1	2397.1
WGN-B3050	548x300x5.2BIS	2598.7	2598.7	2598.7	2598.7	2598.7	2598.7	2598.7	2598.7	2598.7	2598.7	2598.7	2598.7
WGN-B3120	298x300x6.4BIS	2214.0	2214.0	2214.0	2214.0	2214.0	2214.0	2214.0	2214.0	2214.0	2214.0	1643.8	1258.6
WGN-B3130	423x300x6.4BIS	2524.5	2524.5	2524.5	2524.5	2524.5	2524.5	2524.5	2524.5	2524.5	2524.5	2524.5	2524.5
WGN-B3140	548x300x6.4BIS	2835.0	2835.0	2835.0	2835.0	2835.0	2835.0	2835.0	2835.0	2835.0	2835.0	2835.0	2835.0
WGN-B3150	673x300x6.4BIS	3145.2	3145.2	3145.2	3145.2	3145.2	3145.2	3145.2	3145.2	3145.2	3145.2	3145.2	3145.2

* In the context of this manual Reference capacities include Φ factor but not λ and C factors.

Linear interpolation is permissible within the bounds of the tabulation. The accuracy will be approximately within +/- 0.5% Do not extrapolate.

TABLE B-4
 SERVICEABILITY LOAD LIMIT FOR MEMBERS
 SUBJECT TO AXIAL COMPRESSION
CHS, RHS, SHS AND BRS SECTIONS
 buckling about x- axis

PRODUCT CODE	MEMBER DESIGNATION	SERVICEABILITY MEMBER AXIAL COMPRESSION LIMIT P_{sx} kN FOR MEMBERS WITHOUT FULL LATERAL RESTRAINT											
		Effective Length L_{ec} metres											
		1.0	1.5	2.0	2.5	3.0	3.5	4.0	4.5	5.0	6.0	7.0	8.0
WGN-C1000	89CHS	125.2	116.0	65.3	41.8	29.0	21.3	16.3	12.9	10.4	7.3	5.3	4.1
WGN-C7000	152CHS	423.5	423.5	423.5	302.1	209.8	154.1	118.0	93.2	75.5	52.4	38.5	29.5
WGN-C6000	178CHS	616.2	616.2	616.2	598.9	415.9	305.6	233.9	184.8	149.7	104.0	76.4	58.5
WGN-C3000	230CHS	795.9	795.9	795.9	795.9	795.9	677.8	518.9	410.0	332.1	230.6	169.5	129.7
WGN-C4000	293CHS	1002.6	1002.6	1002.6	1002.6	1002.6	1002.6	1002.6	854.0	691.7	480.4	352.9	270.2
WGN-C5000	301CHS	1444.9	1444.9	1444.9	1444.9	1444.9	1444.9	1444.9	1267.0	1026.3	712.7	523.6	400.9
WGN-C8000	356CHS	1721.3	1721.3	1721.3	1721.3	1721.3	1721.3	1721.3	1721.3	1721.3	1204.2	884.7	677.3
WGN-R1000	100x75RHS	152.6	152.6	89.9	57.5	40.0	29.4	22.5	17.8	14.4	10.0	7.3	5.6
WGN-R4000	150x100RHS	747.5	747.5	631.0	403.9	280.5	206.1	157.8	124.6	101.0	70.1	51.5	39.4
WGN-R5000	250x100RHS	219.9	219.9	219.9	219.9	219.9	219.9	219.9	219.9	219.9	188.8	138.7	106.2
WGN-S1000	100SHS	201.4	201.4	119.8	76.7	53.3	39.1	30.0	23.7	19.2	13.3	9.8	7.5
WGN-S3000	125SHS	307.4	307.4	283.1	181.2	125.8	92.4	70.8	55.9	45.3	31.5	23.1	17.7
WGN-B1020	200x100x5.2BRS	402.9	402.9	402.9	402.9	287.2	211.0	161.5	127.6	103.4	71.8	52.7	40.4
WGN-B1030	300x100x5.2BRS	604.4	604.4	604.4	604.4	604.4	604.4	497.4	393.0	318.4	221.1	162.4	124.4
WGN-B1040	400x100x5.2BRS	805.8	805.8	805.8	805.8	805.8	805.8	805.8	805.8	729.1	506.3	372.0	284.8
WGN-B1050	500x100x5.2BRS	1007.3	1007.3	1007.3	1007.3	1007.3	1007.3	1007.3	1007.3	1007.3	972.8	714.7	547.2
WGN-B1120	250x125x6.4BRS	614.8	614.8	614.8	614.8	614.8	496.4	380.0	300.3	243.2	168.9	124.1	95.0
WGN-B1130	375x125x6.4BRS	922.2	922.2	922.2	922.2	922.2	922.2	922.2	921.1	746.1	518.1	380.7	291.5
WGN-B1140	500x125x6.4BRS	1229.6	1229.6	1229.6	1229.6	1229.6	1229.6	1229.6	1229.6	1229.6	1184.6	870.4	666.4
WGN-B1150	625x125x6.4BRS	1536.9	1536.9	1536.9	1536.9	1536.9	1536.9	1536.9	1536.9	1536.9	1536.9	1536.9	1279.8

* In the context of this manual Reference capacities include Φ factor but not λ and C factors.

Linear interpolation is permissible within the bounds of the tabulation. The accuracy will be approximately within +/- 0.5% Do not extrapolate.

TABLE B-4A
 SERVICEABILITY LOAD LIMIT FOR MEMBERS
 SUBJECT TO AXIAL COMPRESSION
BIS SECTIONS
 buckling about x- axis

PRODUCT CODE	MEMBER DESIGNATION	SERVICEABILITY MEMBER AXIAL COMPRESSION LIMIT P_{sx} kN FOR MEMBERS WITHOUT FULL LATERAL RESTRAINT											
		Effective Length L_{ec} metres											
		1.0	1.5	2.0	2.5	3.0	3.5	4.0	4.5	5.0	6.0	7.0	8.0
WGN-B3020	248x300x5.2BIS	1780.6	1780.6	1780.6	1780.6	1780.6	1780.6	1780.6	1780.6	1465.2	1017.5	747.6	572.4
WGN-B3030	348x300x5.2BIS	1967.4	1967.4	1967.4	1967.4	1967.4	1967.4	1967.4	1967.4	1967.4	1967.4	1621.3	1241.3
WGN-B3040	448x300x5.2BIS	2154.1	2154.1	2154.1	2154.1	2154.1	2154.1	2154.1	2154.1	2154.1	2154.1	2154.1	2154.1
WGN-B3050	548x300x5.2BIS	2341.0	2341.0	2341.0	2341.0	2341.0	2341.0	2341.0	2341.0	2341.0	2341.0	2341.0	2341.0
WGN-B3120	298x300x6.4BIS	1989.2	1989.2	1989.2	1989.2	1989.2	1989.2	1989.2	1989.2	1989.2	1543.7	1134.2	868.3
WGN-B3130	423x300x6.4BIS	2280.4	2280.4	2280.4	2280.4	2280.4	2280.4	2280.4	2280.4	2280.4	2280.4	2280.4	1947.7
WGN-B3140	548x300x6.4BIS	2571.5	2571.5	2571.5	2571.5	2571.5	2571.5	2571.5	2571.5	2571.5	2571.5	2571.5	2571.5
WGN-B3150	673x300x6.4BIS	2862.6	2862.6	2862.6	2862.6	2862.6	2862.6	2862.6	2862.6	2862.6	2862.6	2862.6	2862.6

* In the context of this manual Reference capacities include Φ factor but not λ and C factors.

Linear interpolation is permissible within the bounds of the tabulation. The accuracy will be approximately within +/- 0.5% Do not extrapolate.

TABLE B-5
REFERENCE CAPACITIES FOR MEMBERS
SUBJECT TO AXIAL COMPRESSION *
CHS, RHS, SHS AND BRS SECTIONS
buckling about y- axis

PRODUCT CODE	MEMBER DESIGNATION	REFERENCE MEMBER AXIAL COMPRESSION CAPACITIES ΦN_{coy} kN FOR MEMBERS WITHOUT FULL LATERAL RESTRAINT											
		Effective Length L_{ec} metres											
		1.0	1.5	2.0	2.5	3.0	3.5	4.0	4.5	5.0	6.0	7.0	8.0
WGN-C1000	89CHS	292.1	162.4	91.4	58.5	40.6	29.8	22.8	18.0	14.6	10.2	7.5	5.7
WGN-C7000	152CHS	988.2	988.2	660.8	422.9	293.7	215.8	165.2	130.5	105.7	73.4	53.9	41.3
WGN-C6000	178CHS	1437.9	1437.9	1310.1	838.5	582.3	427.8	327.5	258.8	209.6	145.6	106.9	81.9
WGN-C3000	230CHS	1857.1	1857.1	1857.1	1857.1	1291.6	948.9	726.5	574.0	465.0	322.9	237.2	181.6
WGN-C4000	293CHS	2339.5	2339.5	2339.5	2339.5	2339.5	1976.3	1513.1	1195.6	968.4	672.5	494.1	378.3
WGN-C5000	301CHS	3371.4	3371.4	3371.4	3371.4	3371.4	2932.2	2245.0	1773.8	1436.8	997.8	733.0	561.2
WGN-C8000	356CHS	4016.4	4016.4	4016.4	4016.4	4016.4	4016.4	3793.1	2997.0	2427.6	1685.8	1238.6	948.3
WGN-R1000	100X75RHS	152.6	143.2	80.6	51.6	35.8	26.3	20.1	15.9	12.9	9.0	6.6	5.0
WGN-R4000	150X100RHS	1030.5	804.2	452.4	289.5	201.1	147.7	113.1	89.4	72.4	50.3	36.9	28.3
WGN-R5000	250X100RHS	219.9	219.9	219.9	219.9	219.9	176.6	135.2	106.9	86.5	60.1	44.2	33.8
WGN-S1000	100SHS	201.4	201.4	167.7	107.4	74.6	54.8	41.9	33.1	26.8	18.6	13.7	10.5
WGN-S3000	125SHS	307.4	307.4	307.4	253.6	176.1	129.4	99.1	78.3	63.4	44.0	32.4	24.8
WGN-B1020	200x100x5.2BRS	402.9	402.9	336.1	215.1	149.4	109.7	84.0	66.4	53.8	37.3	27.4	21.0
WGN-B1030	300x100x5.2BRS	604.4	604.4	503.8	322.4	223.9	164.5	126.0	99.5	80.6	56.0	41.1	31.5
WGN-B1040	400x100x5.2BRS	805.8	805.8	670.9	429.4	298.2	219.1	167.7	132.5	107.4	74.6	54.8	41.9
WGN-B1050	500x100x5.2BRS	1007.3	1007.3	838.7	536.8	372.8	273.9	209.7	165.7	134.2	93.2	68.5	52.4
WGN-B1120	250x125x6.4BRS	614.8	614.8	614.8	508.0	352.8	259.2	198.5	156.8	127.0	88.2	64.8	49.6
WGN-B1130	375x125x6.4BRS	922.2	922.2	922.2	762.0	529.2	388.8	297.7	235.2	190.5	132.3	97.2	74.4
WGN-B1140	500x125x6.4BRS	1229.6	1229.6	1229.6	1012.4	703.0	516.5	395.5	312.5	253.1	175.8	129.1	98.9
WGN-B1150	625x125x6.4BRS	1536.9	1536.9	1536.9	1266.4	879.4	646.1	494.7	390.9	316.6	219.9	161.5	123.7

* In the context of this manual Reference capacities include Φ factor but not λ and C factors.

Linear interpolation is permissible within the bounds of the tabulation. The accuracy will be approximately within +/- 0.5% Do not extrapolate.

TABLE B-5A
 REFERENCE CAPACITIES FOR MEMBERS
 SUBJECT TO AXIAL COMPRESSION *
BIS SECTIONS
 buckling about y- axis

PRODUCT CODE	MEMBER DESIGNATION	REFERENCE MEMBER AXIAL COMPRESSION CAPACITIES ΦN_{coy} KN FOR MEMBERS WITHOUT FULL LATERAL RESTRAINT											
		Effective Length L_{ec} metres											
		1.0	1.5	2.0	2.5	3.0	3.5	4.0	4.5	5.0	6.0	7.0	8.0
WGN-B3020	248x300x5.2BIS	1994.0	1994.0	1994.0	1994.0	1994.0	1994.0	1892.9	1495.6	1211.5	841.3	618.1	473.2
WGN-B3030	348x300x5.2BIS	2195.6	2195.6	2195.6	2195.6	2195.6	2195.6	1930.3	1525.2	1235.4	857.9	630.3	482.6
WGN-B3040	448x300x5.2BIS	2397.1	2397.1	2397.1	2397.1	2397.1	2397.1	1971.1	1557.4	1261.5	876.0	643.6	492.8
WGN-B3050	548x300x5.2BIS	2598.7	2598.7	2598.7	2598.7	2598.7	2598.7	2014.1	1591.4	1289.0	895.2	657.7	503.5
WGN-B3120	298x300x6.4BIS	2214.0	2214.0	2214.0	2214.0	2214.0	2214.0	2002.8	1582.5	1281.8	890.1	654.0	500.7
WGN-B3130	423x300x6.4BIS	2524.5	2524.5	2524.5	2524.5	2524.5	2524.5	2106.2	1664.2	1348.0	936.1	687.8	526.6
WGN-B3140	548x300x6.4BIS	2835.0	2835.0	2835.0	2835.0	2835.0	2835.0	2215.2	1750.2	1417.7	984.5	723.3	553.8
WGN-B3150	673x300x6.4BIS	3145.2	3145.2	3145.2	3145.2	3145.2	3039.8	2327.3	1838.9	1489.5	1034.4	759.9	581.8

* In the context of this manual Reference capacities include Φ factor but not λ and C factors.

Linear interpolation is permissible within the bounds of the tabulation. The accuracy will be approximately within +/- 0.5% Do not extrapolate.

TABLE B-6
 SERVICEABILITY LOAD LIMIT FOR MEMBERS
 SUBJECT TO AXIAL COMPRESSION
CHS, RHS, SHS AND BRS SECTIONS
 buckling about y- axis

PRODUCT CODE	MEMBER DESIGNATION	SERVICEABILITY MEMBER AXIAL COMPRESSION LIMIT P_{sy} KN FOR MEMBERS WITHOUT FULL LATERAL RESTRAINT											
		Effective Length L_{ec} metres											
		1.0	1.5	2.0	2.5	3.0	3.5	4.0	4.5	5.0	6.0	7.0	8.0
WGN-C1000	89CHS	125.2	116.0	65.3	41.8	29.0	21.3	16.3	12.9	10.4	7.3	5.3	4.1
WGN-C7000	152CHS	423.5	423.5	423.5	302.1	209.8	154.1	118.0	93.2	75.5	52.4	38.5	29.5
WGN-C6000	178CHS	616.2	616.2	616.2	598.9	415.9	305.6	233.9	184.8	149.7	104.0	76.4	58.5
WGN-C3000	230CHS	795.9	795.9	795.9	795.9	795.9	677.8	518.9	410.0	332.1	230.6	169.5	129.7
WGN-C4000	293CHS	1002.6	1002.6	1002.6	1002.6	1002.6	1002.6	1002.6	854.0	691.7	480.4	352.9	270.2
WGN-C5000	301CHS	1444.9	1444.9	1444.9	1444.9	1444.9	1444.9	1444.9	1267.0	1026.3	712.7	523.6	400.9
WGN-C8000	356CHS	1721.3	1721.3	1721.3	1721.3	1721.3	1721.3	1721.3	1721.3	1721.3	1204.2	884.7	677.3
WGN-R1000	100x75RHS	152.6	102.3	57.6	36.8	25.6	18.8	14.4	11.4	9.2	6.4	4.7	3.6
WGN-R4000	150x100RHS	747.5	574.4	323.1	206.8	143.6	105.5	80.8	63.8	51.7	35.9	26.4	20.2
WGN-R5000	250x100RHS	219.9	219.9	219.9	219.9	171.7	126.2	96.6	76.3	61.8	42.9	31.5	24.1
WGN-S1000	100SHS	201.4	201.4	119.8	76.7	53.3	39.1	30.0	23.7	19.2	13.3	9.8	7.5
WGN-S3000	125SHS	307.4	307.4	283.1	181.2	125.8	92.4	70.8	55.9	45.3	31.5	23.1	17.7
WGN-B1020	200x100x5.2BRS	402.9	402.9	240.1	153.6	106.7	78.4	60.0	47.4	38.4	26.7	19.6	15.0
WGN-B1030	300x100x5.2BRS	604.4	604.4	359.9	230.3	159.9	117.5	90.0	71.1	57.6	40.0	29.4	22.5
WGN-B1040	400x100x5.2BRS	805.8	805.8	479.2	306.7	213.0	156.5	119.8	94.7	76.7	53.3	39.1	30.0
WGN-B1050	500x100x5.2BRS	1007.3	1007.3	599.1	383.4	266.3	195.6	149.8	118.3	95.9	66.6	48.9	37.4
WGN-B1120	250x125x6.4BRS	614.8	614.8	567.0	362.9	252.0	185.1	141.8	112.0	90.7	63.0	46.3	35.4
WGN-B1130	375x125x6.4BRS	922.2	922.2	850.5	544.3	378.0	277.7	212.6	168.0	136.1	94.5	69.4	53.2
WGN-B1140	500x125x6.4BRS	1229.6	1229.6	1129.9	723.1	502.2	368.9	282.5	223.2	180.8	125.5	92.2	70.6
WGN-B1150	625x125x6.4BRS	1536.9	1536.9	1413.4	904.6	628.2	461.5	353.3	279.2	226.1	157.0	115.4	88.3

* In the context of this manual Reference capacities include Φ factor but not λ and C factors.

Linear interpolation is permissible within the bounds of the tabulation. The accuracy will be approximately within +/- 0.5% Do not extrapolate.

TABLE B-6A
 SERVICEABILITY LOAD LIMIT FOR MEMBERS
 SUBJECT TO AXIAL COMPRESSION
BIS SECTIONS
 buckling about y- axis

PRODUCT CODE	MEMBER DESIGNATION	SERVICEABILITY MEMBER AXIAL COMPRESSION LIMIT P_{sY} kN FOR MEMBERS WITHOUT FULL LATERAL RESTRAINT											
		Effective Length L_{ec} metres											
		1.0	1.5	2.0	2.5	3.0	3.5	4.0	4.5	5.0	6.0	7.0	8.0
WGN-B3020	248x300x5.2BIS	1780.6	1780.6	1780.6	1780.6	1780.6	1696.5	1298.9	1026.3	831.3	577.3	424.1	324.7
WGN-B3030	348x300x5.2BIS	1967.4	1967.4	1967.4	1967.4	1967.4	1738.7	1331.2	1051.8	852.0	591.6	434.7	332.8
WGN-B3040	448x300x5.2BIS	2154.1	2154.1	2154.1	2154.1	2154.1	1780.9	1363.5	1077.3	872.6	606.0	445.2	340.9
WGN-B3050	548x300x5.2BIS	2341.0	2341.0	2341.0	2341.0	2341.0	1823.1	1395.8	1102.8	893.3	620.4	455.8	349.0
WGN-B3120	298x300x6.4BIS	1989.2	1989.2	1989.2	1989.2	1989.2	1769.3	1354.6	1070.3	867.0	602.1	442.3	338.7
WGN-B3130	423x300x6.4BIS	2280.4	2280.4	2280.4	2280.4	2280.4	1870.4	1432.1	1131.5	916.5	636.5	467.6	358.0
WGN-B3140	548x300x6.4BIS	2571.5	2571.5	2571.5	2571.5	2571.5	1971.6	1509.5	1192.7	966.1	670.9	492.9	377.4
WGN-B3150	673x300x6.4BIS	2862.6	2862.6	2862.6	2862.6	2821.2	2072.7	1586.9	1253.9	1015.6	705.3	518.2	396.7

* In the context of this manual Reference capacities include Φ factor but not λ and C factors.

Linear interpolation is permissible within the bounds of the tabulation. The accuracy will be approximately within +/- 0.5% Do not extrapolate.

TABLE B-7
REFERENCE CAPACITIES * FOR CRUSHING / BEARING CAPACITY OF WGN SECTIONS

Insert Type	Bearing Capacity, kN					
	WGN-S1000 (100SHS)	WGN-S3000 (125SHS)	WGN-R1000 (100x75 RHS)	WGN-R1000 (75x100 RHS)	WGN-R5000 (250x100 RHS)	WGN-R5000 (100x250 RHS)
No insert	9.3	19.9	11.6	15.3	57.7	78.3
With Anti-Crush (Hole Vertical)	94.6	134.0	N/A	86.1	N/A	N/A
With Anti-Crush (Hole Horizontal)	45.4	66.4	60.7	N/A	N/A	N/A

* In the context of this manual Reference capacities include Φ factor but not λ and C factors.

TABLE B-8
REFERENCE CAPACITIES * FOR CRUSHING / BEARING CAPACITY OF WGN SECTIONS WITH GROUT

Insert Type	Bearing Capacity, kN
	Grouted
216.7	

* In the context of this manual Reference capacities include Φ factor but not λ and C factors.

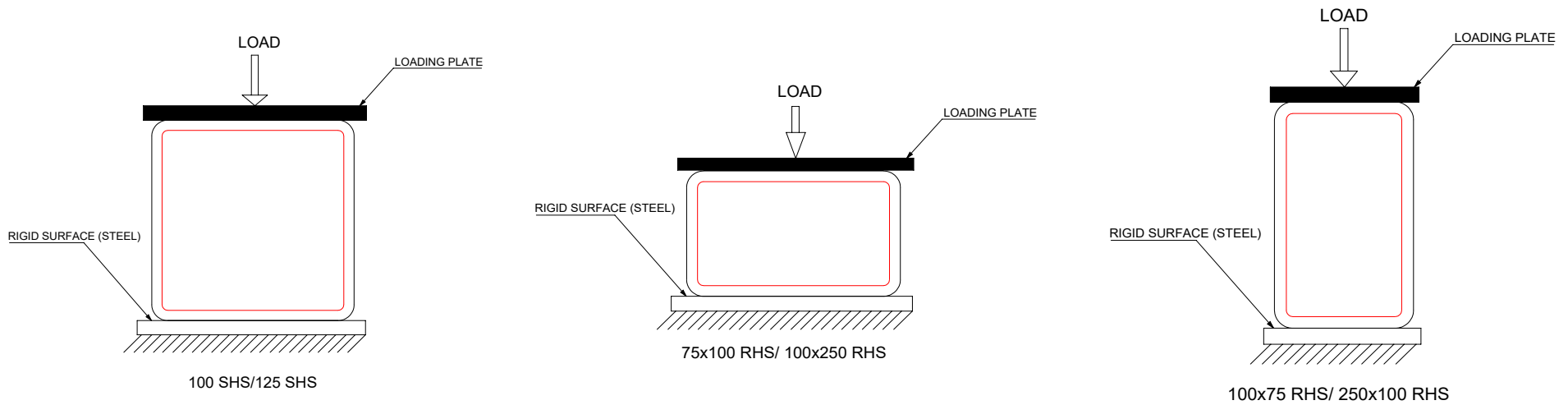

APPENDIX C: CONNECTION CAPACITIES

C. 1: BOLTED CONNECTION CAPACITY

TABLE C-1.1

REFERENCE CAPACITIES * FOR BOLTED CONNECTIONS
SHS SECTIONS USING WAGNERS CFT ANTI-CRUSH BLOCK INSERT
Loaded parallel to the longitudinal fibres

Connection Capacity, kN												
Section	WGN-S1000 (100SHS)											
Bolt Size	M16				M20				M24			
	Single Shear		Double Shear		Single Shear		Double Shear		Single Shear		Double Shear	
	Non-Glued Insert	Glued Insert	Non-Glued Insert	Glued Insert	Non-Glued Insert	Glued Insert	Non-Glued Insert	Glued Insert	Non-Glued Insert	Glued Insert	Non-Glued Insert	Glued Insert
1 Bolt Joint	25.0	40.2	35.2	64.0	25.0	40.2	43.6	64.0	36.1	40.2	72.2	80.4
2 Bolt Joint %	49.9	80.4	70.4	127.9	49.9	80.4	87.3	127.9	72.2	80.4	144.4	160.7
3 Bolt Joint %	74.9	120.5	105.5	191.9	74.9	120.5	130.9	191.9	108.3	120.5	216.6	241.1

Connection Capacity, kN												
Section	WGN-S3000 (125SHS)											
Bolt Size	M16				M20				M24			
	Single Shear		Double Shear		Single Shear		Double Shear		Single Shear		Double Shear	
	Non-Glued Insert	Glued Insert	Non-Glued Insert	Glued Insert	Non-Glued Insert	Glued Insert	Non-Glued Insert	Glued Insert	Non-Glued Insert	Glued Insert	Non-Glued Insert	Glued Insert
1 Bolt Joint	25.9	41.1	64.0	99.0	34.5	41.9	76.6	99.0	39.0	49.8	78.1	99.5
2 Bolt Joint %	51.8	82.3	127.9	198.1	68.9	83.8	153.2	198.1	78.1	99.5	156.1	199.0
3 Bolt Joint %	77.8	123.4	191.9	297.1	103.4	125.7	229.8	297.1	117.1	149.3	234.2	298.6

* Recommended strength for design and evaluated based on characteristic strength in accordance with ASCE Pre-Standard for Load and Resistance Factor Design (LRFD) of Pultruded Fibre Reinforced Polymer (FRP) Structures (Final) (2010). The strengths in the table are to be used in normal ambient condition only.

% Estimated multiple-bolt joints strength with load distribution factor in accordance with ASCE Pre-Standard.

* In the context of this manual Reference capacities include Φ factor but not λ and C factors.

- Using Wagners CFT anti-crush block Insert, connection capacities in the transverse direction can be taken similar to the longitudinal, conservatively.

TABLE C-1.2

REFERENCE CAPACITIES* FOR BOLTED CONNECTIONS
SHS AND RHS SECTIONS
Using 316 stainless steel CHS bush insert**

Connection Capacity, kN												
Section	WGN-S1000 (100SHS)											
Bolt Size	M16				M20				M24			
	Single Shear		Double Shear		Single Shear		Double Shear		Single Shear		Double Shear	
	Tranv.	Long.	Tranv.	Long.	Tranv.	Long.	Tranv.	Long.	Tranv.	Long.	Tranv.	Long.
1 Bolt Joint	10.2	21.7	20.5	43.3	12.9	30.1	25.8	60.1	12.9	33.8	25.8	67.5
2 Bolt Joint %	20.5	43.3	41.0	86.6	25.8	60.1	51.6	120.2	25.8	67.5	51.5	135.0
3 Bolt Joint %	30.7	65.0	61.4	129.9	38.7	90.2	77.4	180.3	38.6	101.3	77.3	202.5

Connection Capacity, kN												
Section	WGN-S3000 (125 SHS)											
Bolt Size	M16				M20				M24			
	Single Shear		Double Shear		Single Shear		Double Shear		Single Shear		Double Shear	
	Tranv.	Long.	Tranv.	Long.	Tranv.	Long.	Tranv.	Long.	Tranv.	Long.	Tranv.	Long.
1 Bolt Joint	11.7	32.6	23.3	65.2	18.0	32.6	36.0	65.2	18.7	42.9	37.3	85.7
2 Bolt Joint %	23.3	65.2	46.7	130.5	36.0	65.2	71.9	130.5	37.3	85.7	74.7	171.4
3 Bolt Joint %	35.0	97.9	70.0	195.7	53.9	97.9	107.9	195.7	56.0	128.6	112.0	257.1

Connection Capacity, kN												
Section	WGN-R5000 (250x100RHS)											
Bolt Size	M16				M20				M24			
	Single Shear		Double Shear		Single Shear		Double Shear		Single Shear		Double Shear	
	Tranv.	Long. ^x	Tranv.	Long. ^x	Tranv.	Long.	Tranv.	Long.	Tranv.	Long.	Tranv.	Long.
1 Bolt Joint	18.2	20.0	36.4	40.0	18.2	50.7	36.4	101.4	18.2	50.7	36.4	101.4
2 Bolt Joint %	36.4	40.0	72.7	80.1	36.4	101.4	72.7	202.7	36.4	101.4	72.7	202.7
3 Bolt Joint %	54.5	60.1	109.1	120.1	54.5	152.1	109.1	304.1	54.5	152.1	109.1	304.1

* Recommended strength for design and evaluated based on characteristic strength in accordance with ASCE Pre-Standard for Load and Resistance Factor Design (LRFD) of Pultruded Fibre Reinforced Polymer (FRP) Structures (Final) (2010). The strengths in the table are to be used in normal ambient condition only.

% Estimated multiple-bolt joints strength with load distribution factor in accordance with ASCE Pre-Standard.

* In the context of this manual Reference capacities include Φ factor but not λ and C factors.

**316SS bush inserts sizes (mm) are 21.3 OD & 2.11 WT, 26.7 OD & 2.11, and 33.4 OD & 3.38 WT for M16, M20 and M24, respectively.

^xConservative experimental value as test was undertaken using bolts only (no SS bush).

TABLE C-1.3
REFERENCE CAPACITIES * FOR BOLTED CONNECTIONS
CHS SECTIONS
Using 316 stainless steel CHS bush insert**

Connection Capacity, kN												
Section	WGN-C7000 (152CHS)											
Bolt Size	M16				M20				M24			
	Single Shear		Double Shear		Single Shear		Double Shear		Single Shear		Double Shear	
	Tranv. ^x	Long.	Tranv. ^x	Long.	Tranv. ^x	Long.	Tranv. ^x	Long.	Tranv. ^x	Long.	Tranv. ^x	Long.
1 Bolt Joint	13.0	29.5	26.0	58.9	15.3	39.6	30.7	79.2	15.7	39.6	31.3	79.2
2 Bolt Joint	26.0	58.9	52.0	117.9	30.7	79.2	61.3	158.3	31.3	79.2	62.6	158.3
3 Bolt Joint	39.0	88.4	78.0	176.8	46.0	118.7	92.0	237.5	47.0	118.7	93.9	237.5

Connection Capacity, kN												
Section	WGN-C6000 (178CHS)											
Bolt Size	M16				M20				M24			
	Single Shear		Double Shear		Single Shear		Double Shear		Single Shear		Double Shear	
	Tranv. ^x	Long.	Tranv. ^x	Long.	Tranv. ^x	Long.	Tranv. ^x	Long.	Tranv. ^x	Long.	Tranv. ^x	Long.
1 Bolt Joint	16.8	21.3	33.6	42.6	23.1	42.2	46.2	84.4	26.3	42.2	52.5	84.4
2 Bolt Joint	33.6	42.6	67.2	85.2	46.2	84.4	92.4	168.8	52.5	84.4	105.0	168.8
3 Bolt Joint	50.4	63.9	100.9	127.7	69.3	126.6	138.7	253.2	78.8	126.6	157.5	253.2

Connection Capacity, kN												
Section	WGN-C3000 (230CHS)											
Bolt Size	M16				M20				M24			
	Single Shear		Double Shear		Single Shear		Double Shear		Single Shear		Double Shear	
	Tranv. ^x	Long. ^x	Tranv. ^x	Long. ^x	Tranv. ^x	Long.	Tranv. ^x	Long.	Tranv. ^x	Long.	Tranv. ^x	Long.
1 Bolt Joint	12.5	25.8	24.9	51.5	22.5	37.2	44.9	74.3	22.5	37.2	44.9	74.3
2 Bolt Joint	24.9	51.5	49.8	103.1	44.9	74.3	89.9	148.6	44.9	74.3	89.9	148.6
3 Bolt Joint	37.4	77.3	74.7	154.6	67.4	111.5	134.8	223.0	67.4	111.5	134.8	223.0

* Recommended strength for design and evaluated based on characteristic strength in accordance with ASCE Pre-Standard for Load and Resistance Factor Design (LRFD) of Pultruded Fibre Reinforced Polymer (FRP) Structures (Final) (2010). The strengths in the table are to be used in normal ambient condition only.

** Estimated multiple-bolt joints strength with load distribution factor in accordance with ASCE Pre-Standard.

* In the context of this manual Reference capacities include Φ factor but not λ and C factors.

**316SS bush inserts sizes (mm) are 21.3 OD & 2.11 WT, 26.7 OD & 2.11, and 33.4 OD & 3.38 WT for M16, M20 and M24, respectively.

^x Conservative experimental value as test was undertaken using bolts only (no SS bush).

SINGLE SHEAR

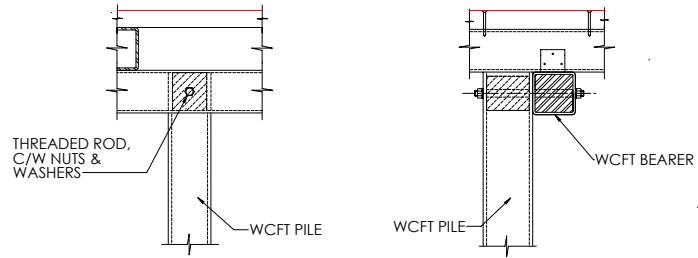

SINGLE SHEAR

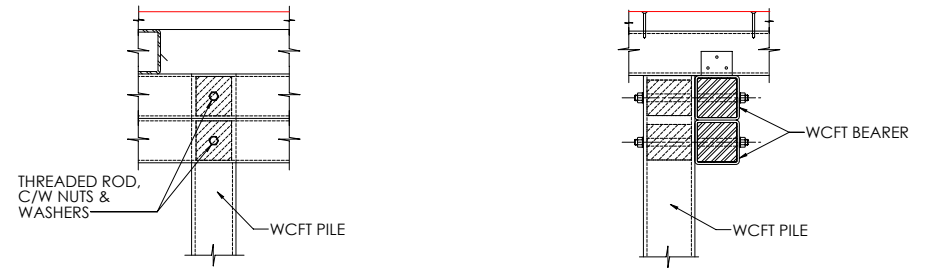

DOUBLE SHEAR

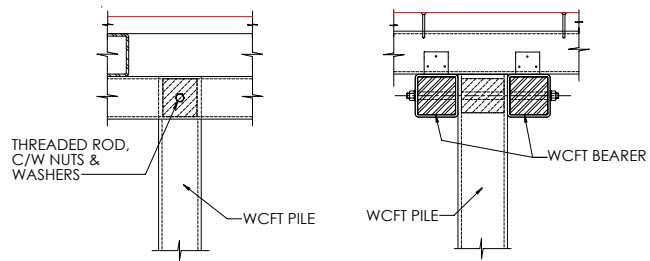

DOUBLE SHEAR

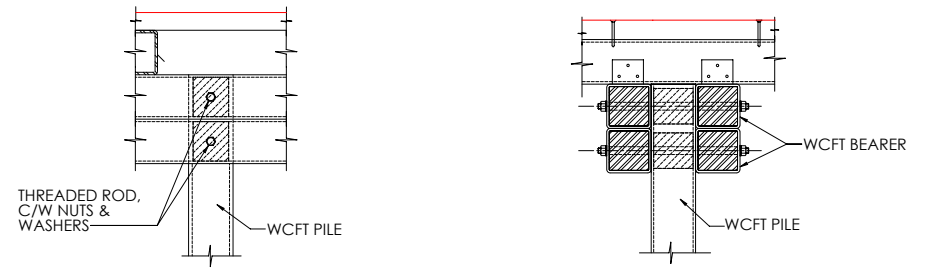

1 BOLT JOINTS

2 BOLT JOINTS

TABLE C-1.4
 REFERENCE CAPACITIES * FOR BOLT PULL-OUT
 With and without anti-crush block inserts

Bolt Pullout Capacity, kN						
Sections	M16		M20		M24	
	No insert	Insert	No insert	Insert	No insert	Insert
WGN-S1000 (100SHS)	12.2	85	14.4	85	16.9	85
WGN-S3000 (125SHS)	13.1	82	15.4	82	26.3	82
WGN-R5000 (100x250RHS)	8.0	87	8.0	87	8.0	87

* Recommended strength for design and evaluated based on characteristic strength in accordance with ASCE Pre-Standard for Load and Resistance Factor Design (LRFD) of Pultruded Fibre Reinforced Polymer (FRP) Structures (Final) (2010). The strengths in the table are to be used in normal ambient condition only.

% Estimated multiple-bolt joints strength with load distribution factor in accordance with ASCE Pre-Standard.

* In the context of this manual Reference capacities include Φ factor but not λ and C factors.

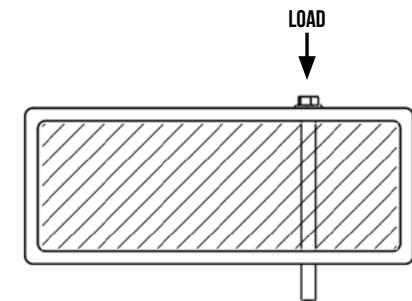
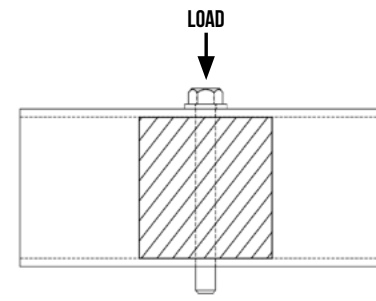
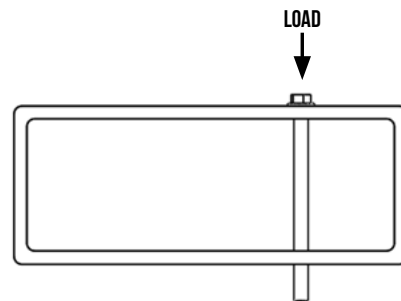
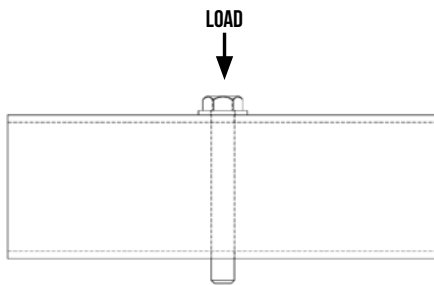
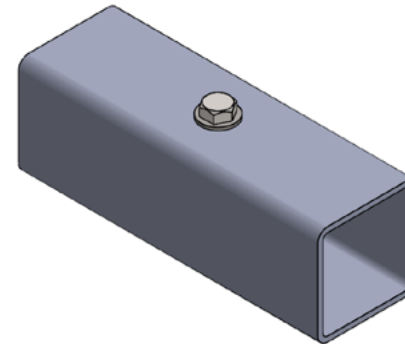
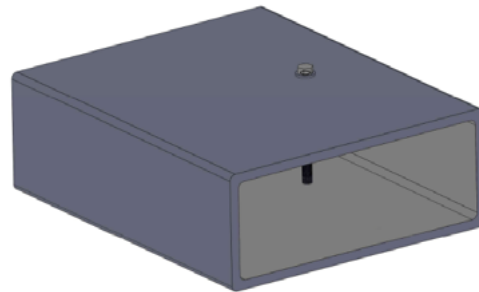

WITH NO INSERT

WITH ANTI CRUSH BLOCK INSERT

C.2: RIVETED CONNECTION CAPACITY

TABLE C-2.1 REFERENCE CAPACITIES * FOR RIVETED-BRACKET CONNECTION BETWEEN WGN SECTIONS Loaded out-of-plane	
Section	Connection Capacity, kN Per Bracket
Bearer - WGN-S1000 (100SHS)	4.5
Bearer - WGN-S3000 (125SHS)	6.2

4.8mm rivet, 316 Stainless steel.

3mm bracket, 316 Stainless Steel.

* In the context of this manual Reference capacities include Φ factor but not λ and C factors.

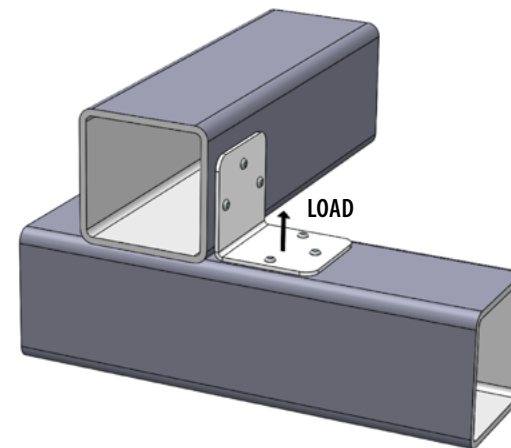
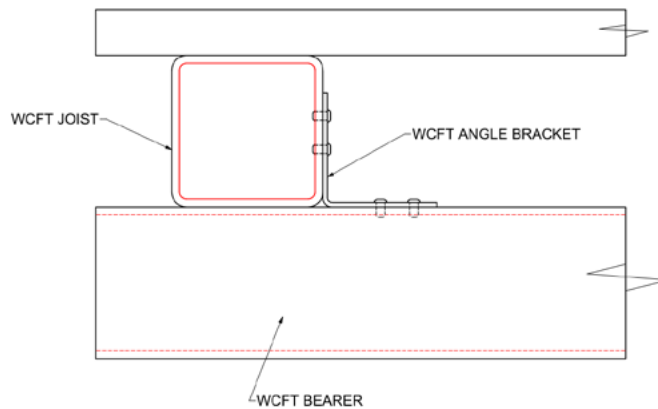
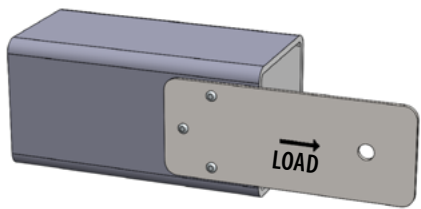

TABLE C-2.2 REFERENCE CAPACITIES * FOR RIVETED-BRACKET CONNECTION BETWEEN WGN SHS SECTIONS General purpose			
Section	No of rivets	Connection Capacity, kN Single Shear	
		Parallel	Transverse
WGN-R1000 (100x75RHS)	1	4.6	5.0
	3	11.5	12.8
WGN-S1000 (100SHS)	1	3.4	4.8
	3	13.4	13.6
WGN-S3000 (125SHS)	1	4.3	4.0
	3	13.6	14.0

4.8mm rivet, 316 Stainless steel.

3mm bracket, 316 Stainless steel.

* In the context of this manual Reference capacities include Φ factor but not λ and C factors.



3 RIVETS - PARALLEL

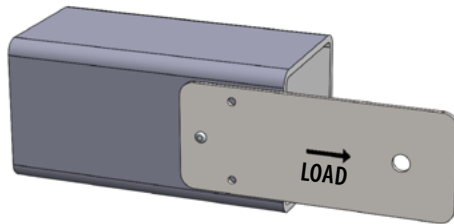

1 RIVETS - PARALLEL

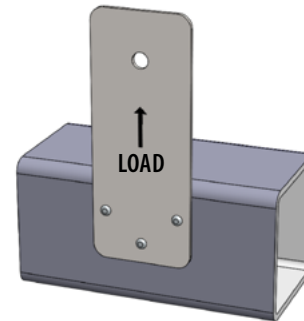

3 RIVETS - TRANSVERSE

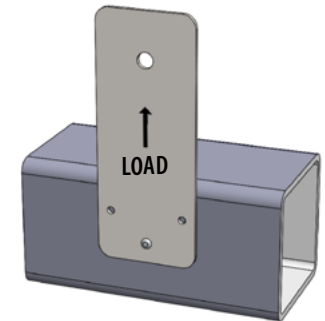

1 RIVETS - TRANSVERSE

TABLE C-2.3 REFERENCE CAPACITIES * FOR STRUCTURAL RIVETED CONNECTIONS BETWEEN WGN SECTIONS Loaded parallel to the longitudinal fibres	
Section	Connection Capacity, kN One Rivet-Single Shear
WGN-S1000 (100SHS)	7.7

6.5mm rivet, 316 Stainless steel.
 3mm bracket, 316 Stainless steel.

*In the context of this manual Reference capacities include Φ factor but not λ and C factors.

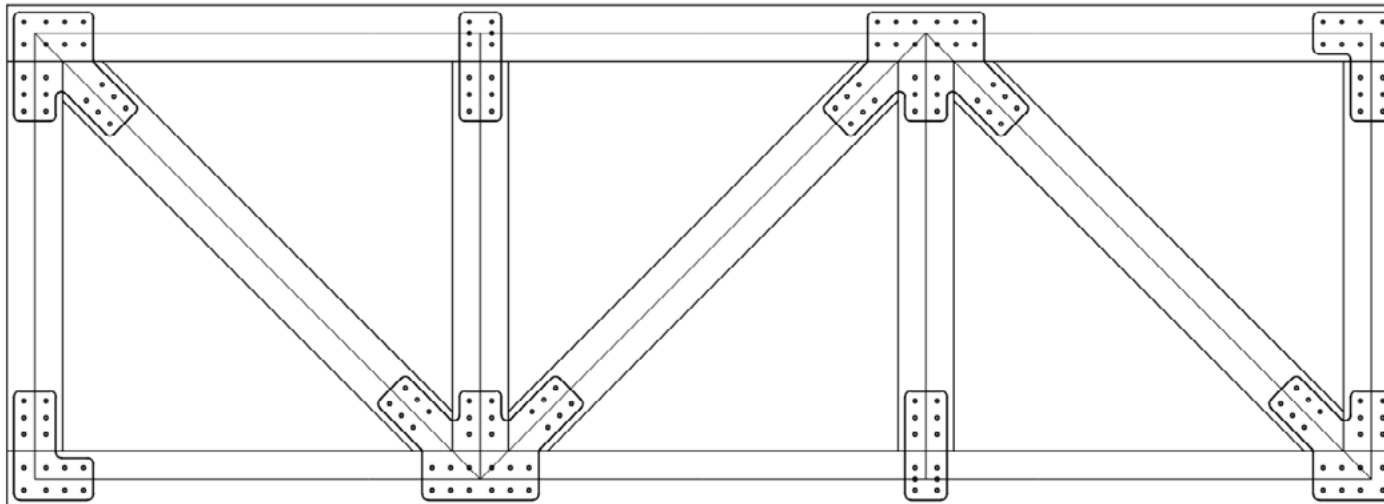
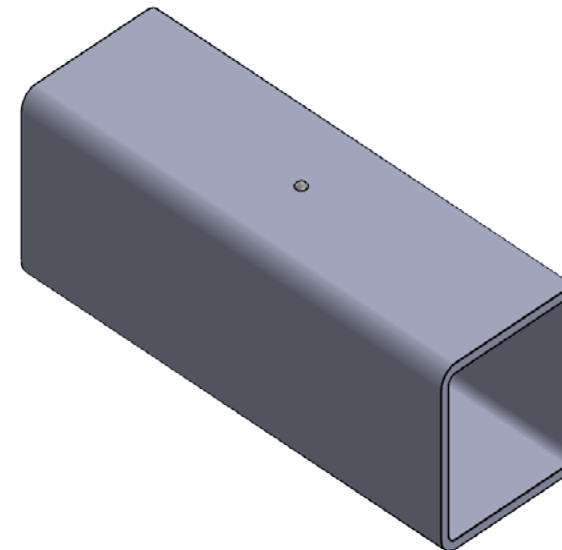
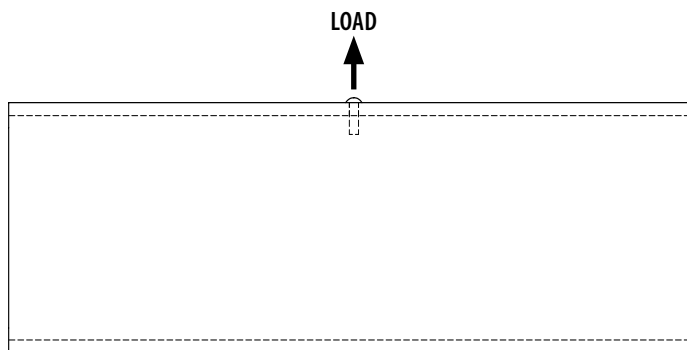

TABLE C-2.4 REFERENCE CAPACITIES* FOR RIVET PULLOUT	
Section	Connection Capacity, kN Single Rivet
WGN-S1000 (100SHS)	2.9

4.8mm rivet, 316 Stainless steel

*In the context of this manual Reference capacities include Φ factor but not λ and C factors.



C.3: DECKING TO JOIST

TABLE C-3
REFERENCE CAPACITIES* FOR SCREWED JOIST-DECKING CONNECTION

Section	Connection Capacity, kN	
	Z-Direction Per Screw	X and Y-Direction Per Two Screws
WGN-S1000 (100SHS)	2.9	2.1
WGN-S3000 (125SHS)	4.8	1.7

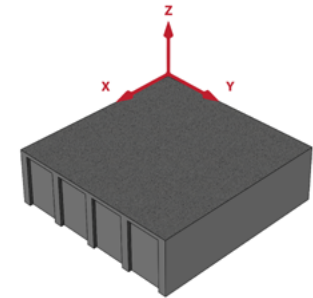

14G bugle batten self-tapping screws, 75mm long.

* In the context of this manual Reference capacities include Φ factor but not λ and C factors.

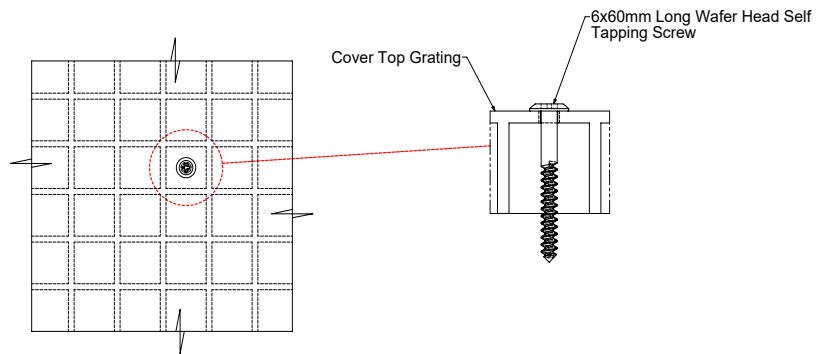

SELF TAPPING SCREW - COVERTOP

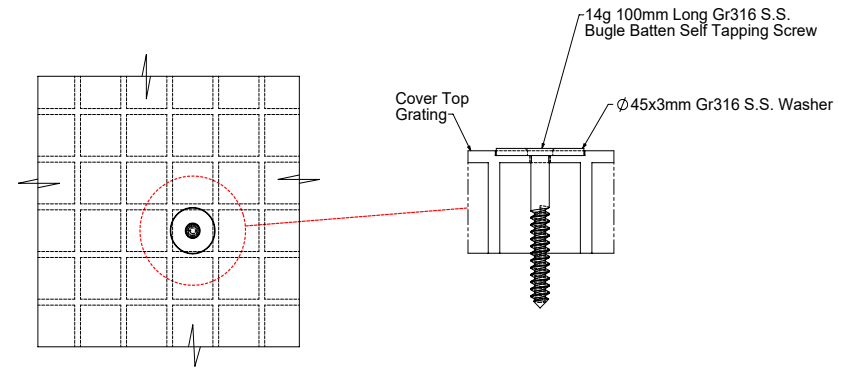

SELF TAPPING SCREW WITH OVERSIZE WASHER - COVERTOP

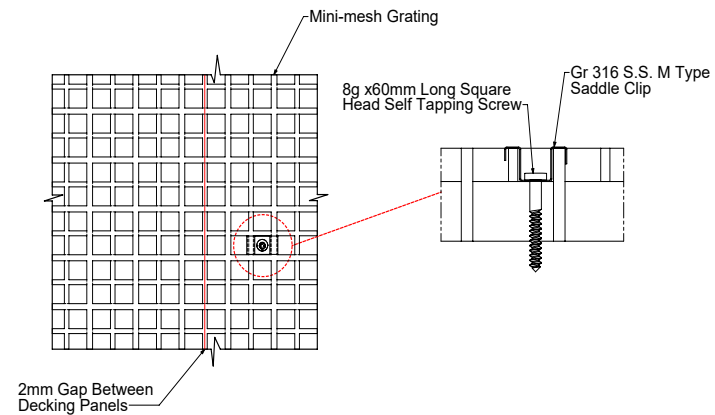
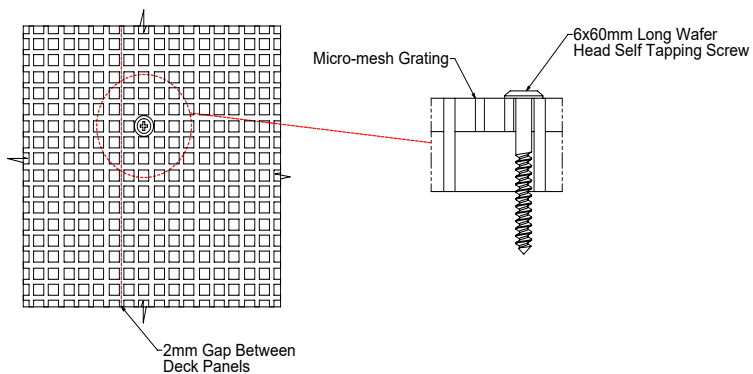

C.4: HANDRAIL CONNECTION

TABLE C-4 REFERENCE CAPACITIES* FOR RIVETED OFFSET RAIL CONNECTION		
Section	Connection Capacity, kN Per Bracket	
	WGN-S1000 (100SHS)	75mm handrail
	6.1	2.7

14G bugle batten self-tapping screws, 75mm long.

* In the context of this manual Reference capacities include Φ factor but not λ and C factors.

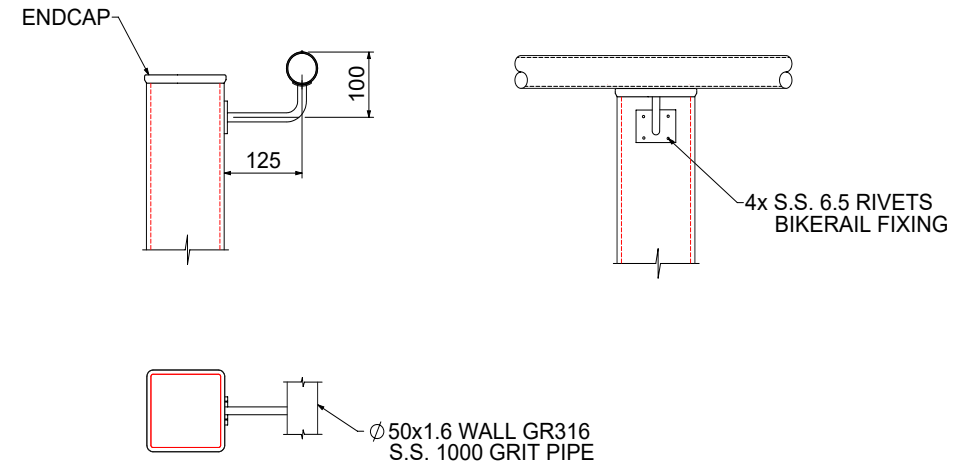

HANDRAIL 125

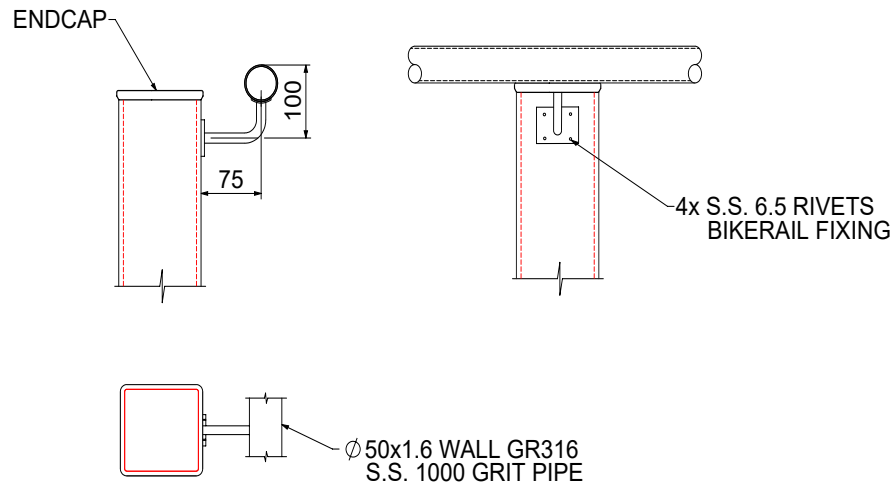

HANDRAIL 75

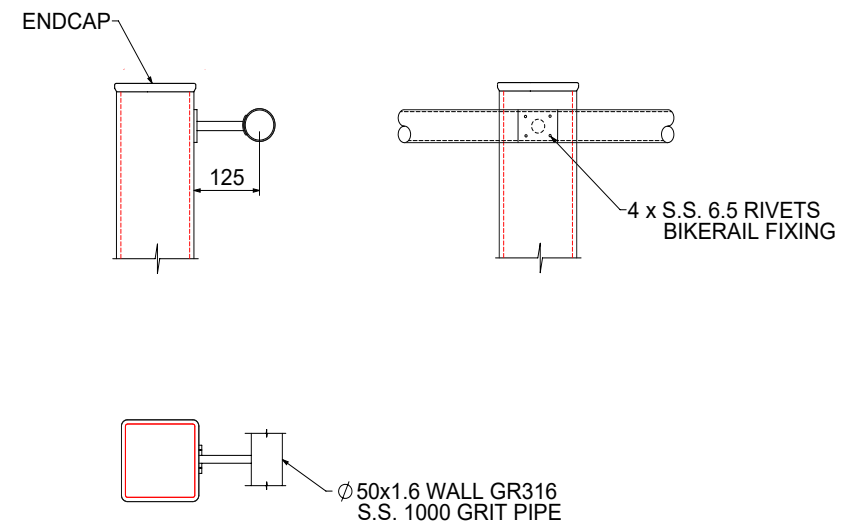

HANDRAIL STRAIGHT POST 125

APPENDIX D: FRP COMPOSITE DECKING

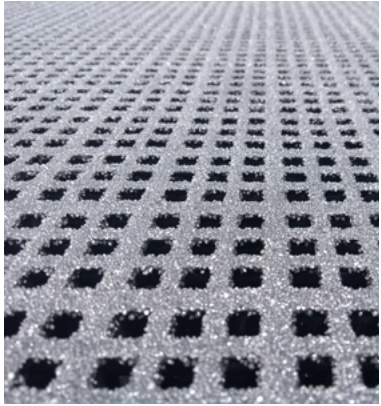

MICRO-MESH DECKING*															
PRODUCT CODE	Thickness (mm)	Bar Thickness (mm)	Bar Spacing (Top/Bottom) (mm)	Aperture (mm)	Open Rate (%)	Panel Size (mm)	Weight (kg/m ²)	Slip Rating (AS4586)	Live UDL Loading	Serviceability Design Load [®]					
										Max. Joists Clear Centres, mm					
										400	600	750	1000	1200	1500
MIC30-XX	30	5.0	13x13 40x40	8x8	38	Standard Size: 1247x3687 Maximum Size: 1527x4047	19.1	P5	≤ 5 kPa	5.5	3.6	2.7	1.6	n/a	n/a
MIC38-XX	38	5.0	13x13 40x40	8x8	38	Standard Size: 1247x3687 Maximum Size: 1527x4047	25.0	P5	≤ 5 kPa	13.0 [^]	4.8	4.3	2.8	1.9	n/a

MINI-MESH DECKING															
PRODUCT CODE	Thickness (mm)	Bar Thickness (mm)	Bar Spacing (Top/Bottom) (mm)	Aperture (mm)	Open Rate (%)	Panel Size (mm)	Weight (kg/m ²)	Slip Rating (AS4586)	Live UDL Loading	Serviceability Design Load [®]					
										Max. Joists Clear Centres, mm					
										400	600	750	1000	1200	1500
MIN30-XX	30	6.5	19x19 38x38	12.5x 12.5	43	Standard Size: 1220x3660 Maximum Size: 1530x4047	18.8	P5	≤ 5 kPa	5.5	3.6	2.7	1.6	n/a	n/a
MIN38-XX	38	6.5	19x19 38x38	12.5x 12.5	43	Standard Size: 1225x3660 Maximum Size: 1225x4047	23.5	P5	≤ 5 kPa	13.0 [^]	4.8	4.3	2.8	1.9	n/a
MIN50-XX	50	5	25x25 50x50	20x20	67	Standard Size: 1225x3660	22	P5	≤ 5 kPa	7.9 [*]	7.9	6.9	3.2	2.2	1.4

Example:

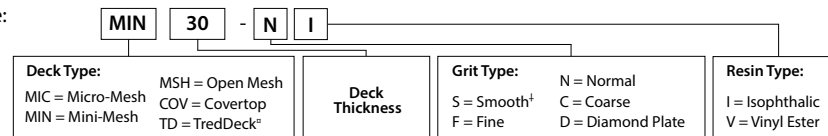

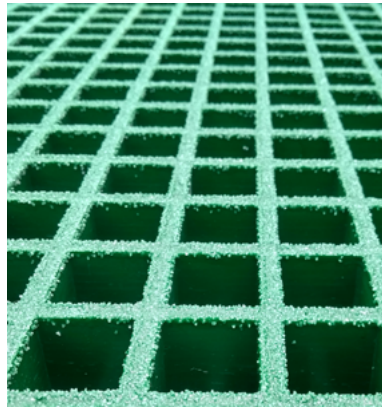

OPEN-MESH DECKING															
PRODUCT CODE	Thickness (mm)	Bar Thickness (mm)	Bar Spacing (Top/Bottom) (mm)	Aperture (mm)	Open Rate (%)	Panel Size (mm)	Weight (kg/m ²)	Slip Rating (AS4586)	Live UDL Loading	Serviceability Design Load [®]					
										Max. Joists Clear Centres, mm					
										400	600	750	1000	1200	1500
MSH38-XX	38	7.0	38x38	31x31	67	Standard Size: 1220x3660 Maximum Size: 2100x4240	19.5	P5	≤ 5 kPa	3.5*	3.5	2.8	1.7	n/a	n/a
MSH50-XX [^]	50	7.0	50x50	43x43	74	Standard Size: 1220x3660 Maximum Size: 1527x4020	23.0	P5	≤ 5 kPa	7.7*	7.7	6.9	3.2	2.4	1.5



COVERTOP DECKING																
PRODUCT CODE	Thickness (mm)	Bar Thickness (mm)	Bar Spacing (mm)	Aperture (mm)	Open Rate (%)	Panel Size mm	Weight (kg/m ²)	Slip Rating (AS4586)	Live UDL Loading	Serviceability Design Load [®]						
										Max. Joists Clear Centres, mm						
										400	600	750	1000	1200	1500	2000
COV25-XX	25	7.0	38x38	0	0	Standard Size: 1220x3660 Maximum Size: 1524x4010	21.0	P5	≤ 5 kPa	5.0	3.6	3.0	1.5	n/a	n/a	n/a
COV30-XX	30	7.0	38x38	0	0	Standard Size: 1220x3660 Maximum Size: 1530x4010	23.0	P5	≤ 5 kPa	6.1	4.4	3.1	1.9	1.8	n/a	n/a
COV43-XX	43	7.0	38x38	0	0	Standard Size: 1220x3660 Maximum Size: 2100x4240	29.0	P5	≤ 5 kPa	13.0 [^]	7.6	7.0	4.6	3.2	n/a	n/a
COV55-XX	55	7.0	50x50	0	0	Standard Size: 1220x3660 Maximum Size: 1527x4020	33.0	P5	≤ 5 kPa	20.0*	20.0 ^x	13.9 [^]	8.4	5.8	3.8	n/a
COV70-XX [^]	70	8.0	38x38	0	0	Standard Size: 1220x3660	59.8	P5	≤ 5 kPa	40.0*	40.0	31.0	21.7	15.2	9.6	5.4

Example:

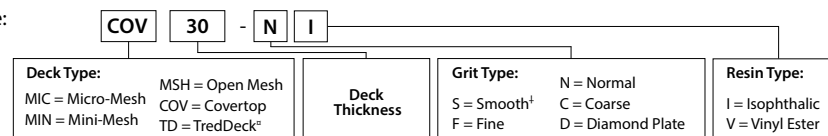



TREDDECK DECKING*																
PRODUCT CODE	Thickness (mm)	Bar Thickness (mm)	Bar Spacing (mm)	Aperture (mm)	Open Rate (%)	Panel Size (mm)	Weight (kg/m ²)	Slip Rating (AS4586)	Live UDL Loading	Serviceability Design Load [®]						
										Max. Joists Clear Centres, mm						
										400	600	750	1000	1200	1500	2000
TD35-FX	35	7.0	38x38	0	0	Standard Size: 1220x3660 Maximum Size: 1524x4010	45.0	P5	≤ 5 kPa	5.0	3.6	3.0	1.5	n/a	n/a	n/a
TD40-FX	40	7.0	38x38	0	0	Standard Size: 1220x3660 Maximum Size: 1530x4010	47.0	P5	≤ 5 kPa	6.1	4.4	3.1	1.9	1.8	n/a	n/a
TD53-FX	53	7.0	38x38	0	0	Standard Size: 1220x3660 Maximum Size: 2100x4240	53.0	P5	≤ 5 kPa	13.0 [^]	7.6	7.0	4.6	3.2	n/a	n/a
TD65-FX	65	7.0	50x50	0	0	Standard Size: 1220x3660 Maximum Size: 1527x4020	57.0	P5	≤ 5 kPa	20.0 [*]	20.0 ^x	13.9 [^]	8.4	5.8	3.8	n/a
TD80-FX [^]	80	8	38x38	0	0	Standard Size: 1220x3660	83.8	P5	≤ 5 kPa	40.0 [*]	40.0	31.0	21.7	15.2	9.6	5.4

• Test load was applied over 100x100mm plate at mid-span and adjacent to the free edge of two-span decking

* Untested, conservative value based on the closest decking type/span

[^] 150x150mm loading plate

^x 200x200mm loading plate

[®] TredDeck comes with fine grit only

[†] Smooth finish has low slip resistance

[®] Refer to Section 11.1 design assumptions of decking spans

Example:

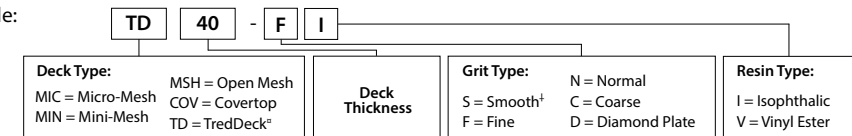

APPENDIX E: WAGNERS CFT CHS PILING TECHNICAL DATA

TABLE E-1
SECTIONAL AND MECHANICAL PROPERTIES
OF WAGNERS CFT CHS PILES

PROPERTY	NOTATION	UOM	VALUE						
			WGN-C1000	WGN-C7000	WGN-C6000	WGN-C3000	WGN-C4000	WGN-C5000	WGN-C8000
			89x6mm Circular Hollow Section	152x8mm Circular Hollow Section	178x10mm Circular Hollow Section	230x9.7mm Circular Hollow Section	293x9.5mm Circular Hollow Section	301x13.5mm Circular Hollow Section	356x13.5mm Circular Hollow Section
Outer Dimension	D_o	mm	88.9	151.9	177.9	230.15	293	301	356
Wall Thickness	t	mm	6	7.9	9.85	9.7	9.5	13.5	13.5
Cross Sectional Area	A	mm ²	1563	3574	5200	6716	8461	12193	14526
Surface Area	SA	m ² /m	0.28	0.48	0.56	0.72	0.92	0.95	1.12
Moment of Inertia	I	mm ⁴	1.35x10 ⁶	9.29x10 ⁶	18.42x10 ⁶	40.89x10 ⁶	85.10x10 ⁶	126.26x10 ⁶	213.33x10 ⁶
Weight	w	kg/m	3.13	7.4	10.56	13.5	17.06	24.64	29.49
Moment Capacity	M_u	kN.m	17 [^]	48 [^]	92 [^]	130 [#]	132 [#]	250 [#]	384 [#]
Tensile Strength (L)	F_{Lt}	MPa	400	635	635	635	635	635	635
Tensile Modulus (L)	E_{Lt}	MPa	32510	35405	35405	35405	35405	35405	35405
Compressive Strength (L)	F_{Lc}	MPa	267	395	395	395	395	395	395
Compressive Modulus (L)	E_{Lc}	MPa	39200	41178	41178	41178	41178	41178	41178
In Plane Shear Stress (L)	F_{Lv}	MPa	52	93	93	93	93	93	93

[^] Experimental moment capacity obtained from full-scale four-point bend test as per ASTM D6109. In cantilever configurations (ASTM D1036), presented moment capacities are less by no more than 20%.

[#] Experimental moment capacity obtained from full-scale cantilever pole test as per ASTM D1036.

* In the conte* In the context of this manual Reference capacities include Φ factor but not λ and C factors.

APPENDIX F: ACCESSORIES

F.1 ANTI-CRUSH INSERTS

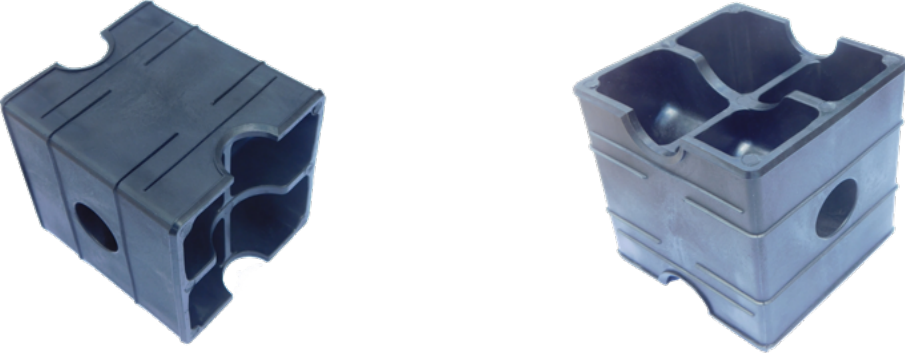

The inserts are manufactured using the injection molding process and are made from lightweight and durable glass fibre-filled thermoplastic alloy which is corrosion and pest resistant.

They are provided at all bolt hole locations to improve the crushing resistance as well as bolted connection capacity.

ANTI-CRUSH INSERT DESCRIPTION	
	
Part Numbers	Application
INST-S3000-Φ14	WGN-S3000-M12 Bolt
INST-S3000-Φ18	WGN-S3000-M16 Bolt
INST-S3000-Φ22	WGN-S3000-M20 Bolt
INST-S3000-Φ26	WGN-S3000-M24 Bolt
INST-S1000-Φ14	WGN-S1000-M12 Bolt
INST-S1000-Φ18	WGN-S1000-M16 Bolt
INST-S1000-Φ22	WGN-S1000-M20 Bolt
INST-S1000-Φ26	WGN-S1000-M24 Bolt
INST-R1000-Φ22	WGN-R1000-M20 Bolt
INST-R1000-Φ26	WGN-R1000-M24 Bolt

F.2 ENDCAPS

Wagners can supply a range of custom manufactured plastic accessories to complement the composite structures. Made from lightweight and durable thermoplastic alloy, all endcap accessories are corrosion resistant and designed to match the long life of the composite asset.

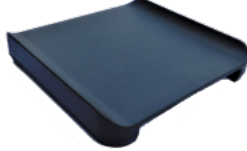
NORMAL ENDCAP		FLUSH ENDCAP		RIVETED METAL ENDCAP		TEE-PIECE	
							
Part Number	Application	Part Number	Application	Part Number	Application	Part Number	Application
NCAP-S1000	WGN-S1000	FCAP-S1000	WGN-S1000	MCAP-S1000	WGN-S1000	TCAP-S1000	WGN-S1000
NCAP-S3000	WGN-S3000	FCAP-S3000	WGN-S3000	MCAP-S3000	WGN-S3000	TCAP-R1000	WGN-R1000
NCAP-R1000	WGN-R1000	FCAP-R1000	WGN-R1000	MCAP-R1000	WGN-R1000	-	-

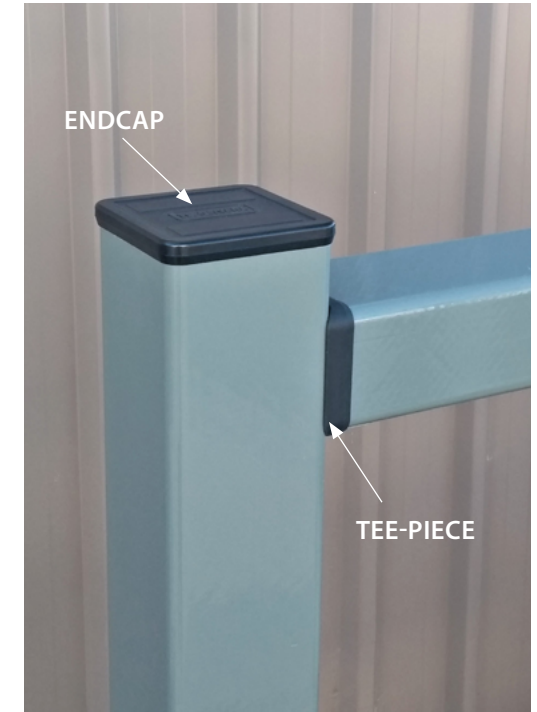

F.3 STANDARD BRACKETS

Various type of stainless steel bracket are used for the connections of Wagners CFT FRP structures. The most common ones are presented below, however, custom made bracket can be easily fabricated to suit different connection configurations.

JOIST-BEARER BRACKET		RAIL-POST BRACKET		ADAPTOR BRACKET	
Part Number	Application	Part Number	Application	Part Number	Application
PA003-01-001	Joist Bearer Connection	PA003-01-002	Rail-Post Connection	PA003-01-006-??	Adaptor

SHOE BRACKET		RAIL BRACKET		TRUSS CHORD TO WEB BRACKET	
Part Number	Application	Part Number	Application	Part Number	Application
PA003-04-004-??	PILE FISH PLATE SHOE BKT	PA003-07-101	RIVETED BIKERAIL BKT	PA003-05-101	Truss Bridges

GLOSSARY

Term	Description
Additives	Substances added to the polymer resin to aid in the processing of the FRP material.
Adhesive	A substance capable of holding materials together by surface attachment.
Composite	A combination of high modulus, high strength and high aspect ratio reinforcing material encapsulated by and acting in concert with a polymeric matrix.
Cure	To change the properties of a thermosetting resin irreversibly by chemical reaction, i.e. condensation, ring-closure, or addition. Cure may be accomplished by addition of curing (cross-linking) agents, with or without catalyst, and with or without heat.
Fibre Reinforced Polymer (FRP)	A Fibre Reinforced Polymer (or plastic) material consists of a polymer resin based matrix reinforced by fibres of either glass, carbon or aramid, and hybrid combinations of these fibre types.
Fibre	One or more filaments in the form of a continuous strand or roving in an FRP material.
Fibre mass fraction	The mass of reinforcement fibre in a cured composite divided by the mass of the composite section.
Fibre orientation	The orientation or alignment of the longitudinal axis of the fibre with respect to a stated reference axis.
Fibre volume fraction	The volume of reinforcement fibre in a cured composite divided by the volume of the composite section.
Filler	Non adhesive substance added in the matrix or adhesive material to alter its engineering properties, performance, and/or cost.
Glass fibre	A fibre spun from an inorganic product of fusion which has cooled to a rigid condition without crystallisation.
Glass transition temperature	Temperature at which the polymer matrix changes from a glassy to a rubbery state as temperature increases.

Term	Description
Matrix	The continuous constituent of an FRP material that surrounds the fibres. It consists of a polymer resin with fillers and additives.
Orthotropic	Having three mutually perpendicular planes of elastic symmetry.
Plastic	A material that contains one or more organic polymers of large molecular weight, is a solid in its finished state and at some stage of its manufacture or processing into finished articles, can be shaped by flow.
Polymer	An organic material composed of molecules characterised by the repetition of one or more types of monomeric units.
Pultrusion	A continuous manufacturing process used to manufacture constant cross-section shapes of any length.
Release agent	An additive which promotes release from the manufacturing mould.
Resin	The polymeric material used to bind together the reinforcing fibres in FRP.
Resin content	The amount of matrix present in a composite either by percent weight or by percent volume.
Resin system	A mixture of resin, with ingredients such as catalyst, initiator (curing agent), diluents, etc. required for the intended processing and final product.
Roving / Tow	Large number of continuous parallel filaments or a group of untwisted parallel strands.
Thermoplastic	A plastic that repeatedly can be softened by heating and hardened by cooling through a temperature range characteristic of the plastic, and when in the softened stage, can be shaped by flow into articles by moulding or extrusion.
Thermoset	A plastic that is substantially infusible and insoluble after being cured by heat or other means, e.g. polyester, epoxy, phenolic resin.
Veil	A thin layer of mat similar to a surface mat, often composed of organic fibres as well as glass fibres.
Vinyl ester resin	Thermosetting resins that consist of a polymer backbone with an acrylate or methacrylate termination.

SUMMARY OF CHANGES

No.	Amendment No. 1 (2024)
1	Revised general wording and formatting in sections 1.1, 1.2, 1.4, 1.6, 2.1, 2.3.1, 2.3.2, 2.4, 2.5.1, 2.5.2, 2.5.4, 2.5.5, 2.8, 2.9, 3.1, 3.2, 3.5.1, 4.1, 4.2, 4.3, 4.5, 4.6, 5.1, 5.2, 5.2.1, 6.1, 9, 10.2.3.1
2	Correcting the design moment capacity calculation for short term loading in the design example (page 56).
3	Member designations are added in all section properties, sections capacities, and members capacities tables.
4	New CHS sections are added to the tables in section A1.1 .
5	A new RHS section is added to the tables in section A1.3 .
6	Design values are rounded to a single decimal.
7	Updating the mechanical properties of flat sections in section A1.4 .
8	New CHS and RHS sections are added in Table B-1 and Table B-5 .
9	Updating the moment capacities of BRS sections in Table B-1 with experimental capacities.
10	Updating the moment capacities and shear capacities of BIS sections in Table B-1A .
11	Updating Table B-2 to include the new sections and moment capacities.
12	Updating the member moment capacities of BIS sections in Table B-2A .
13	Added CHS sections and included all RHS and SHS sections in Table B-3 .
14	<ul style="list-style-type: none"> - New CHS and RHS sections are added in Table B-4 and Table B-6. - Values are updated as the minimum of the serviceability load or reference axial capacities.
15	<ul style="list-style-type: none"> - Updating the characteristic design values of WGN-R1000 as per ASCE Pre-standard CI 2.3.2.1 and including WGN-R5000 in Table B-7. - Illustrative schematic bearing capacity diagrams are added.
16	Correcting bolted connection capacities in Table C-1.1 as per ASCE Pre-Standard and updating experimental capacities of M24 bolt.
17	Adding Table C-1.2 and Table C-1.3 , to present bolted connection capacities of SHS, RHS, and CHS sections with stainless steel CHS bush insert.
18	Adding Table C-1.4 , to present bolt pull out capacities of SHS and RHS sections.
19	Adding Table C-2.4 , to present rivet pull out capacity of SHS section.
20	Correcting the riveted offset rail bracket connection capacity in Table C.4 as per ASCE Pre-Standard.
21	Updating the design loads of FRP composite decking, and added MIN50-XX, MSH50-XX, COV70-XX and TD80-FX in Appendix D .
22	Added Wagners CFT CHS piling technical data in Appendix E .

NOTES

NOTES



DESIGN GUIDE

Published by Wagners CFT Manufacturing Pty Ltd

ABN 91 099 936 446

© Wagners CFT Manufacturing Pty Ltd

Head Office

11 Ballera Court, Wellcamp
Queensland
Australia 4350

Postal Address

PO Box 151
Drayton North
Toowoomba Qld 4350, Australia

Telephone +61 7 4637 7777

Fax +61 7 4637 7778

cftsales@wagner.com.au

www.wagner.com.au



WAGNERS HAS PIONEERED THE USE OF COMPOSITE MATERIALS BOTH IN AUSTRALIA AND INTERNATIONALLY, EXPORTING PRODUCTS ALL AROUND THE WORLD.

VISIT WAGNERS CFT WEBSITE BY SCANNING THE QR CODE

